

GLOBEL®

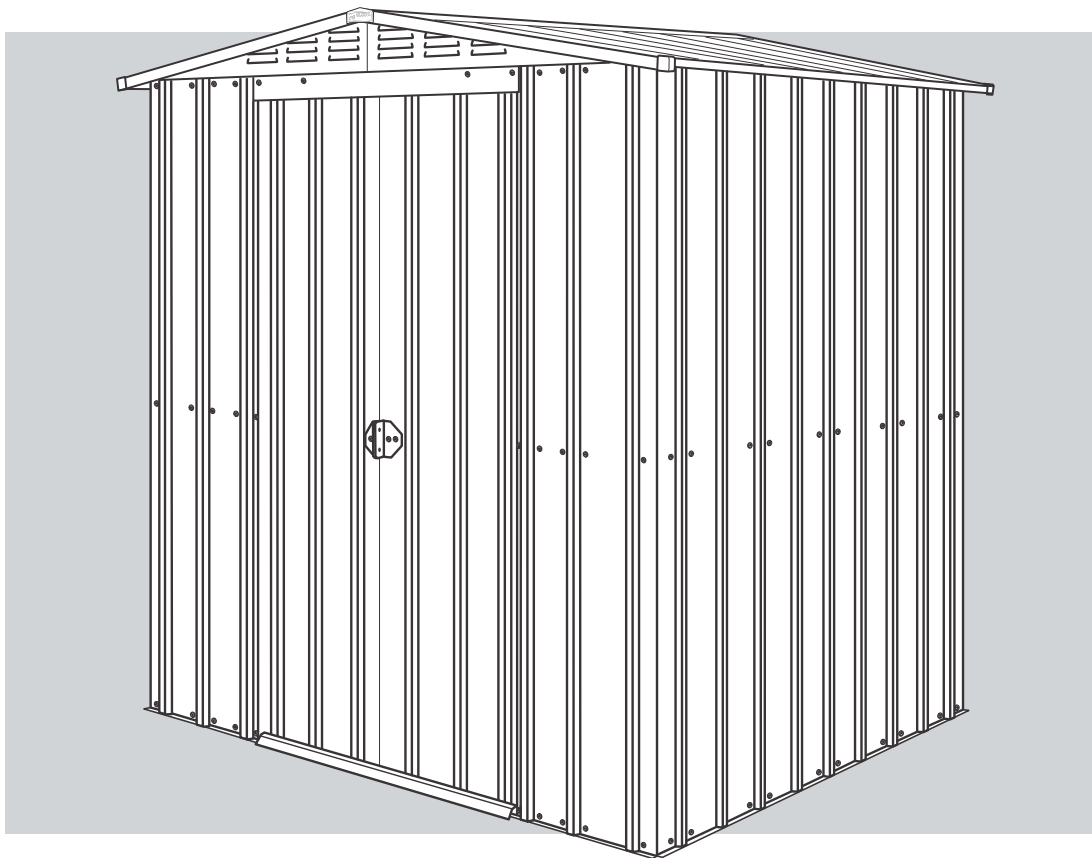

GB ASSEMBLY

CZ SESTAVENÍ

SK MONTÁŽNY NÁVOD

PL MONTAŻ

HU ÖSSZESZERELÉS

INSTALLATION

IMPORTANT - Read These Instructions FIRST.

- Check parts supplied
- This manual illustrates the construction of a 6' wide shed, with additional instructions for other sizes shown where applicable
- Use washers only where indicated
- 2 person assembly recommended
- Assembly recommended on concrete slab or foundation kit and secured with dyna bolts
- Apply sealant along inside of base rail to prevent water seepage

LEGEND

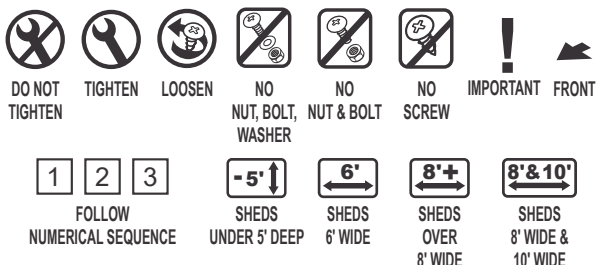

NOTE: SIZE IN FEET NOMINAL ONLY

SAFETY



TOOLS & FIXINGS (NOT INCLUDED)

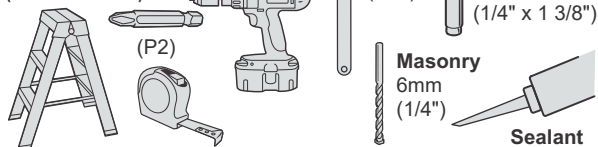

MONTÁŽ

DŮLEŽITÉ - Nejprv si přečítajte tieto pokyny

- Skontrolujte dodané diely
- Tento návod znázorňuje zostavenie 6' širokého záhradného domčeka ako aj ďalšie inštrukcie pre iné rozmery
- Použite podložky len tam kde sú vyznačené
- Pri montáži sa odporúčajú dve osoby
- Montáž sa odporúča na betonovej platni alebo podkladovej výbave, ktorá je zaistená skrutkami Dyna
- Naneste tiesniaci prostriedok pozdĺž vnútornej strany hlavného nosníka aby sa zamedžilo presakovaniu vody

POPIS



POZNÁMKA: ROZMER V STOPÁCH LEN PRE FORMÁLNE ÚČELY

BEZPEČNOSŤ



NÁRADIE & SPOJOVACÍ MATERIÁL (NEZAHŔŔA)

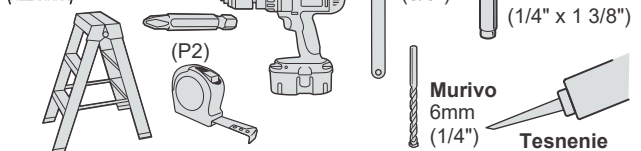

INSTALOVÁNÍ

DŮLEŽITÉ - Přečtěte si NEJPRVĚ tento návod.

- Zkontrolujte dodané součástky
- Tato příručka znázorňuje konstrukci zahradního domku o šíři 6' s možností dodání dalšího návodu pro jiné velikosti tam kde příslušné
- Používejte kovové podložky pouze tam kde je to naznačené
- Doporučujeme, aby instalaci prováděli 2 osoby
- Doporučujeme provést sestavení na betonové desce nebo základové soupravě a zabezpečit šrouby Dyna
- Naneste těsnící hmotu podél vnitřního spodního hrzení, aby tam nezatekala voda

POPISEK



POZNÁMKA: VELIKOSTI POUZE VE STOPÁCH

BEZPEČNOST



NÁRADÍ & SOUČÁSTI (NENÍ ZAHŔŔENO)

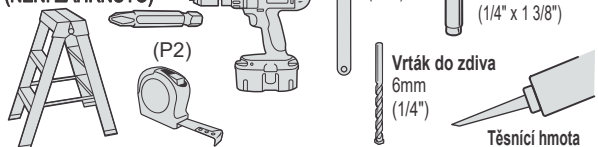

INSTALACJA

WAŻNE - Przeczytaj te instrukcje NAJPIERW

- Sprawdź dostarczone części
- Niniejszy podręcznik ilustruje budowę szopy szerokości 6 stóp, z dodatkowymi instrukcjami uwzględniającymi inne rozmiary
- Używaj podkładek tylko tam, gdzie wskazano
- Zalecane montowanie przez 2 osoby
- Zaleca się montowanie na betonowej płycie lub zestawie fundamentowym zabezpieczonym śrubami dyna
- Nalóż szczeliwo wzdłuż szyny bazowej by zapobiec przeciekom wody

LEGENDA



UWAGA: ROZMIAR JEDYNNIE W STOPACH

BEZPIECZEŃSTWO



NARZĘDZIA I ŁĄCZNIKI (NIE ZAŁĄCZONE)

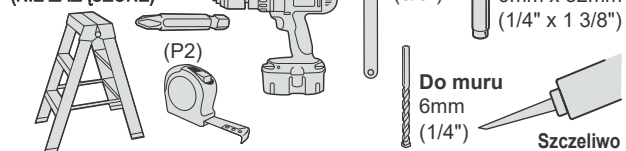

FELSZERELÉS

FONTOS – Olvassa el ezeket az utasításokat ELŐBB

- Ellenőrizze a kapott alkatrészeket
- Ez a segédlet leírja, hogy hogy kell egy 6 láb széles sufnit összeállítani, valamint további utasítást ad más nagyságúakra, ahol ez alkalmazható
- Csak a megjelölt helyen használja a csavaralátétet
- Javasoljuk, hogy 2 személy szerelje össze
- Javasoljuk, hogy betonlapon vagy alapozó készleten szerelje össze és dyna csapszeggel erősítse meg
- Tegyen tömítőszeret az alaprács mentén belül, hogy ne szivároгjon víz

MAGYARÁZÓ FELIRAT

NE RÖGÍTSE
SZOROSABBRARÖGÍTSE
SZOROSABBRALAZÍTSA
MEGNEM KELL SE
ANYACSAVAR, SE
CSAPSZEG,
SE CSAVARALÁTÉTNEM KELL SE
ANYACSAVAR,
SE CSAPSZEGNEM KELL
CSAVAR

FONTOS

ELEJE

1 2 3

KÖVESSE A
SZÁMSORRENDET

-5'

5 LÁBNÁL
KEVÉSBÉ
SZÉLES SUFNIK

6'

6 LÁB
SZÉLESSÉGŰ
SUFNIK

8'+

8 LÁBNÁL
SZÉLESEBB
SUFNIK

8' & 10'

8 LÁB &
10 LÁB
SZÉLESSÉGŰ
SUFNIK

FIGYELEM: LÁB NAGYSÁG CSAK NOMINÁLIS

BIZTONSÁG



Éles szélek –
Kezelje óvatosan.
Viseljen védő kesztyűt.



Fulladásveszély.
Kis részecskéket
tartalmaz

SZERSZÁMOK & KELLÉKEK

(EZT NEM TARTALMAZZA)

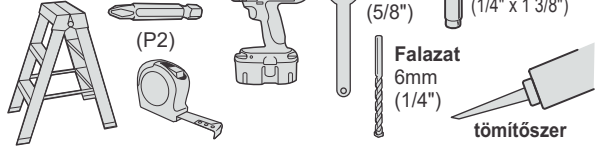

(P2)

6mm
(5/8")Dyna csapszegek
6mm x 32mm
(1/4" x 1 3/8")Falazat
6mm
(1/4")

tömítőszer

A SOLID FOUNDATION IS RECOMMENDED

This page shows recommended method and dimensions. Make sure site is firm and level, and water drains away from site.

A

Determine size of recommended concrete slab foundation. (See Diagram A)

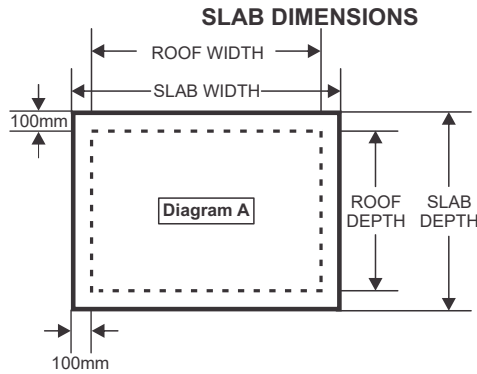

B

Make sure slab area is square by ensuring diagonal corner dimensions are equal. (Diagram B)

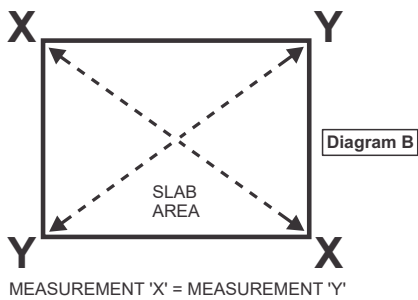

C

Formwork must be 100mm thick and level. (Diagram C)

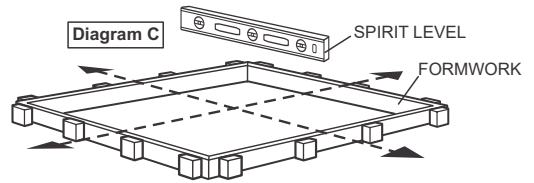

D

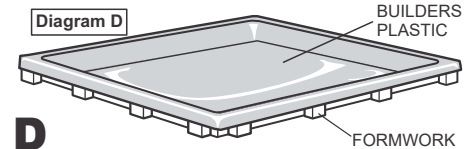

D

Lay builders plastic on ground as barrier to rising moisture. (Diagram D)

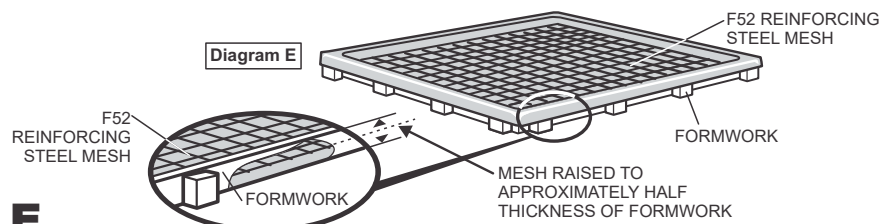

E

Place F52 reinforcing steel mesh on top of builders plastic, ensuring steel mesh is raised off plastic to depth of approximately half thickness of formwork. (Diagram E). Pour concrete. Allow five days to cure.

DOPORUČUJEME PEVNÝ ZÁKLAD

Tato stránka ukazuje doporučenou metodu a rozměry. Zajistěte, aby místo bylo pevné a v rovině a voda odtékala z místa.

A

Je potřeba určit velikost betonové desky / základu (viz Diagram A)

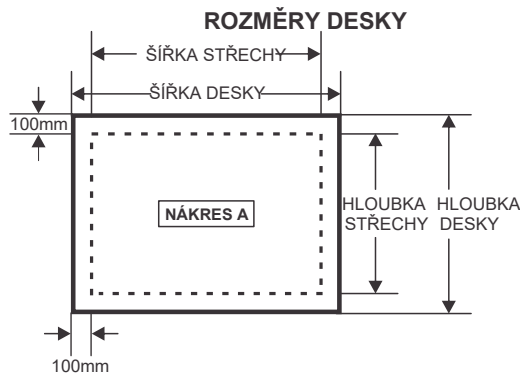

B

Čtyřhranost plochy desky zajistěte tak, že rozměry diagonálních rohů budou stejné (Diagram B)

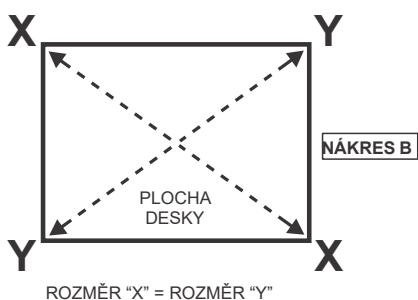

C

Rámeček musí být 100mm silný a v rovině. (Diagram C)

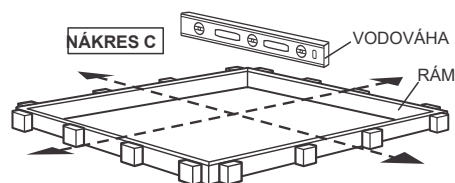

D

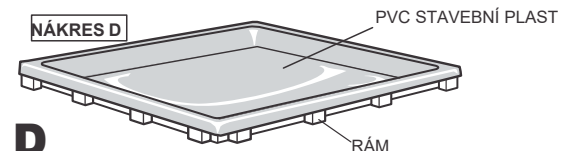

D

Položte stavební plast na zem jako bariéru proti stoupající vlhkosti.

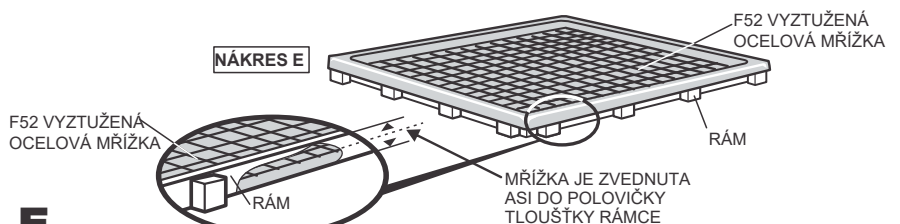

E

Umístěte ocelovou mřížku F52 na stavební plast a zajistěte, aby mřížka byla zvednuta nad plastem přibližně do poloviny tloušťky rámce. (Diagram E). Nalijte beton. Nechejte 5 dní vytvrdit.

ODPORÚČA SA PEVNÝ PODKLAD

Táto strana znázorňuje odporúčaný postup a rozmery. Uistite sa, že stavebná plocha je pevná a rovná a voda z nej odtieká

A

Určte veľkosť betónového panelu/ podklad je nutný (viď Náčres A)

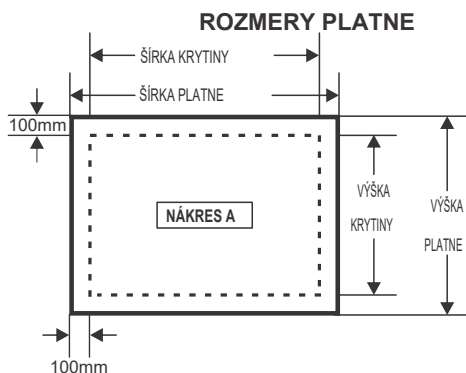

B

Uistite sa, že plocha platne má tvar štvorca tým, že rozmery uhlopriečok sú rovnaké (Náčres B)

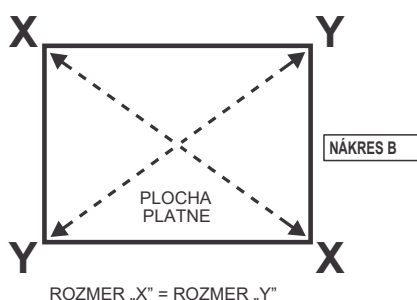

C

Debnenie musí byť 100mm hrubé a rovné (Náčres C)

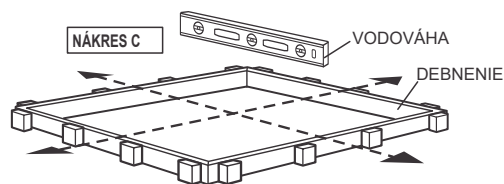

D

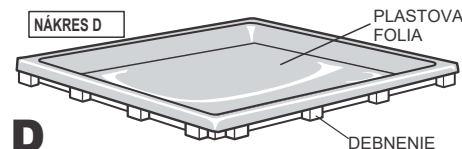

Položte plastovú fóliu na dno aby sa zamedzilo vzniku vlhkosti. (Náčres D)

D



E

Upevňujúce oceľové pletivo F52 umiestnite na vrch plastovej fólie tak aby oceľové pletivo bolo vyzdvihnuté nad fóliou do výšky približne polovičnej hrúbky debnenia. (Náčres E). Zalejte betón. Nechajte tvrdnúť 5 dní.

ZALECA SIĘ ZBUDOWANIE FUNDAMENTU

Ta strana pokazuje zalecaną metodę i rozmiary. Dopilnuj, by miejsce było twarde i spoziomowane, a ścieki oddalone od miejsca postawienia.

A

Ustal rozmiar wymaganego betonowego fundamentu. (zob. Rysunek A)

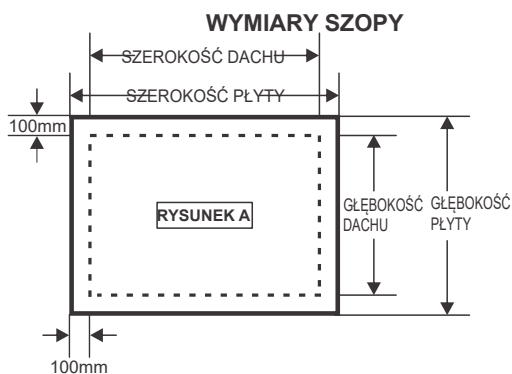

B

Dopilnuj, by powierzchnia płyty była kwadratowa sprawdzając, że długości przekątnych od rogu są równe (Rysunek B)

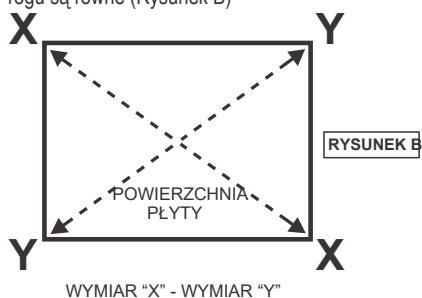

C

Szalunek musi być 100mm grubości i spoziomowany. (Rysunek C)

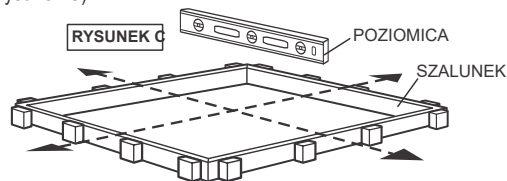

D

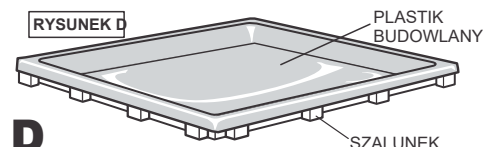

Rozłóż plastik budowlany na ziemi, jako barierę przed wilgocią od spodu. (Rysunek D)

D

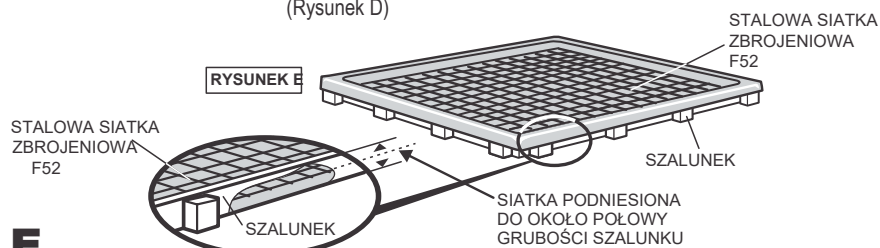

E

Umieść stalową siatkę zbrojeniową F52 na plastiku budowlanym, dopilnowując, by siatka stalowa była uniesiona nad plastikiem do głębokości około połowy grubości szalunku. (Rysunek E). Wlej beton. Przeznacz 5 dni na stwardnienie.

SZILÁRD ALAPOZÁST JAVASOLUNK

Ez az oldal mutatja az ajánlott módszert és a méreteket. Győződjön meg, hogy a hely szilárd és egyszintű és hogy a víz a helyről elfolyik.

A

Állapítsa meg, hogy milyen nagy betonlap/ alapozás szükséges. (Lásd az A ábrát)

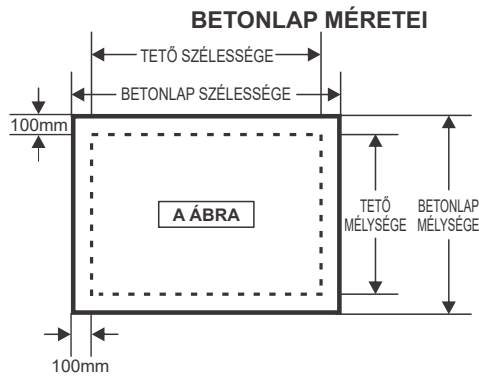

B

Győződjön meg, hogy a betonlap helye négyszögletes gondoskodva arról, hogy az átlós sarokméretek egyenlőek legyenek (B ábra)

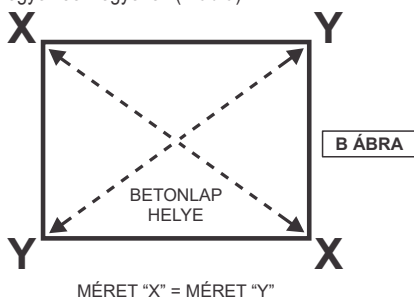

C

Zsaluzatnak 100 milliméter szélesnek és vízintésnek kell lennie (C ábra)

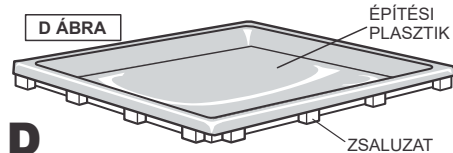
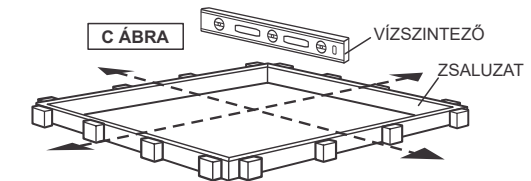

D

Tegyen építési plastikot a földre, hogy megakadályozza a nedvesség felszívargását (D ábra)

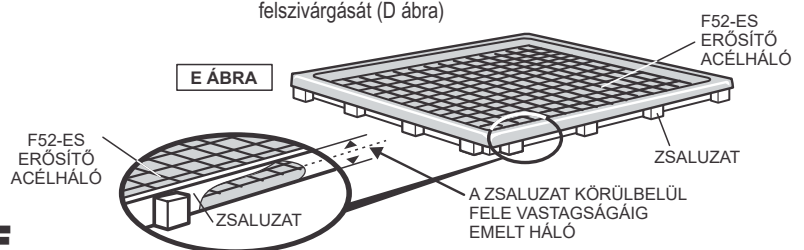

E

Tegye az F52-es erősítő acélhálót az építési plastikra, gondoskodva arról, hogy az acélháló a zsaluzat körülbelül fele vastagságáig legyen emelve. (E ábra) öntse ki a betont. Hagyja 5 napig száradni.

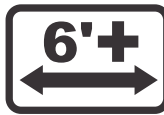

	3'↑	4'↑	5'↑	6'↑	7'↑	8'↑	9'↑	10'↑	11'↑	12'↑
100	4	4	6	6	8	8	10	10	12	12
101		2		2		2		2		2
102	4	4	4	4	4	4	4	4	4	4
103	2	2	2	2	2	2	2	2	2	2
105-475-3	2	2	2	2	2	2	2	2	2	2
106	2	2	4	4	6	6	8	8	10	10
107		2		2		2		2		2
108	4	4	4	4	4	4	4	4	4	4
109	1	1	1	1	1	1	1	1	1	1
110-464-TLBR-X	2	2	2	2	2	2	2	2	2	2
110-464-TRBL-X	2	2	2	2	2	2	2	2	2	2
112	2	2	2	2	2	2	2	2	2	2
113	2	2	2	2	2	2	2	2	2	2
114	1	1	2	2	2	2	2	2	2	2
115		1		1	2	3	4	5	6	7
116-1218-X		2			2		2			
116-1529-X			2				2		4	4
173-686-X									2	2
176-907-X	2				2					
177-930-X				4						
178-1240.5-X						4				
179-1551.5-X								4		
200	1	1	1	1	1	1	1	1	1	1
201	1	1	1	1	1	1	1	1	1	1
202	1	1	1	1	1	1	1	1	1	1
203	1	1	1	1	1	1	1	1	1	1
204	2	2	2	2	2	2	2	2	2	2
205	1	1	1	1	1	1	1	1	1	1
206	2	2	2	2	2	2	2	2	2	2
207	2	2	2	2	2	2	2	2	2	2
208	2	2	2	2	2	2	2	2	2	2
209	2	2	2	2	2	2	2	2	2	2
210	1	1	1	1	1	1	1	1	1	1
300	2	2	2	2	2	2	2	2	2	2
301	2	2	2	2	2	2	2	2	2	2
302	6	6	6	6	6	6	6	6	6	6
303	16	16	16	16	16	16	16	16	16	16
304	4	4	4	4	4	4	4	4	4	4
305	4	4	4	4	4	4	4	4	4	4
306	2	2	2	2	2	2	2	2	2	2
309					2	2	2	2	2	2
310	4	4	4	4	4	4	4	4	4	4
311	2	2	2	2	2	2	2	2	2	2
312	1 x	1 x	1 x	1 x	1 x	1 x	1 x	1 x	1 x	1 x
313	1 x	1 x	1 x	1 x	1 x	1 x	1 x	1 x	1 x	1 x
314	1 x	1 x	1 x	1 x	1 x	1 x	1 x	1 x	1 x	1 x
315	200	200	200	200	200	200	200	200	200	200

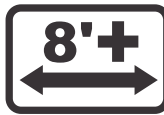

	3'↑	4'↑	5'↑	6'↑	7'↑	8'↑	9'↑	10'↑	11'↑	12'↑
100	5	5	7	7	9	9	11	11	13	13
101	2	4	2	4	2	4	2	4	2	4
102	4	4	4	4	4	4	4	4	4	4
103	2	2	2	2	2	2	2	2	2	2
105-550-3	2	2	2	2	2	2	2	2	2	2
106	2	2	4	4	6	6	8	8	10	10
107		2		2		2		2		2
108	4	4	4	4	4	4	4	4	4	4
109	1	1	1	1	1	1	1	1	1	1
110-520-TLBR-X	2	2	2	2	2	2	2	2	2	2
110-520-TRBL-X	2	2	2	2	2	2	2	2	2	2
112	2	2	2	2	2	2	2	2	2	2
113	2	2	2	2	2	2	2	2	2	2
114	1	1	2	2	2	2	2	2	2	2
115		1		1	2	3	4	5	6	7
116-1218-X		2			2		2			
116-1529-X			2				2		4	4
173-686-X									2	2
176-907-X	2				2					
177-930-X				4						
178-1240.5-X						4				
179-1551.5-X								4		
200	1	1	1	1	1	1	1	1	1	1
201	1	1	1	1	1	1	1	1	1	1
202	1	1	1	1	1	1	1	1	1	1
203	1	1	1	1	1	1	1	1	1	1
204	2	2	2	2	2	2	2	2	2	2
205	1	1	1	1	1	1	1	1	1	1
206	2	2	2	2	2	2	2	2	2	2
207	2	2	2	2	2	2	2	2	2	2
208	2	2	2	2	2	2	2	2	2	2
209	2	2	2	2	2	2	2	2	2	2
210	1	1	1	1	1	1	1	1	1	1
300	2	2	2	2	2	2	2	2	2	2
301	2	2	2	2	2	2	2	2	2	2
302	6	6	6	6	6	6	6	6	6	6
303	16	16	16	16	16	16	16	16	16	16
304	4	4	4	4	4	4	4	4	4	4
305	4	4	4	4	4	4	4	4	4	4
306	2	2	2	2	2	2	2	2	2	2
309					2	2	2	2	2	2
310	4	4	4	4	4	4	4	4	4	4
311	2	2	2	2	2	2	2	2	2	2
312	1 x	1 x	1 x	1 x	1 x	1 x	1 x	1 x	1 x	1 x
313	1 x	1 x	1 x	1 x	1 x	1 x	1 x	1 x	1 x	1 x
314	1 x	1 x	1 x	1 x	1 x	1 x	1 x	1 x	1 x	1 x
315	200	200	200	200	200	200	200	200	200	200



	3'↑	4'↑	5'↑	6'↑	7'↑	8'↑	9'↑	10'↑	11'↑	12'↑
100	8	8	10	10	12	12	14	14	16	16
101		2		2		2		2		2
102	4	4	4	4	4	4	4	4	4	4
103	2	2	2	2	2	2	2	2	2	2
105-550-3	2	2	2	2	2	2	2	2	2	2
106	2	2	4	4	6	6	8	8	10	10
107		2		2		2		2		2
108	4	4	4	4	4	4	4	4	4	4
109	1	1	1	1	1	1	1	1	1	1
110-520-TLBR-X	2	2	2	2	2	2	2	2	2	2
110-520-TRBL-X	2	2	2	2	2	2	2	2	2	2
112	2	2	2	2	2	2	2	2	2	2
113	2	2	2	2	2	2	2	2	2	2
114	1	1	2	2	2	2	2	2	2	2
115		1		1	2	3	4	5	6	7
116-1218-X		2			2		2			
116-1529-X			2				2		4	4
173-686-X									2	2
176-907-X	2				2					
177-930-X				4						
178-1240.5-X						4				
179-1551.5-X								4		
200	1	1	1	1	1	1	1	1	1	1
201	1	1	1	1	1	1	1	1	1	1
202	1	1	1	1	1	1	1	1	1	1
203	1	1	1	1	1	1	1	1	1	1
204	2	2	2	2	2	2	2	2	2	2
205	1	1	1	1	1	1	1	1	1	1
206	2	2	2	2	2	2	2	2	2	2
207	2	2	2	2	2	2	2	2	2	2
208	2	2	2	2	2	2	2	2	2	2
209	2	2	2	2	2	2	2	2	2	2
210	1	1	1	1	1	1	1	1	1	1
211	2	2	2	2	2	2	2	2	2	2
212	2	2	2	2	2	2	2	2	2	2
300	2	2	2	2	2	2	2	2	2	2
301	2	2	2	2	2	2	2	2	2	2
302	6	6	6	6	6	6	6	6	6	6
303	16	16	16	16	16	16	16	16	16	16
304	4	4	4	4	4	4	4	4	4	4
305	4	4	4	4	4	4	4	4	4	4
306	2	2	2	2	2	2	2	2	2	2
307	2	2	2	2	2	2	2	2	2	2
308	2	2	2	2	2	2	2	2	2	2
309					2	2	2	2	2	2
310	4	4	4	4	4	4	4	4	4	4
311	2	2	2	2	2	2	2	2	2	2
312	1 x	1 x	1 x	1 x	1 x	1 x	1 x	1 x	1 x	1 x
313	1 x	1 x	1 x	1 x	1 x	1 x	1 x	1 x	1 x	1 x
314	1 x	1 x	1 x	1 x	1 x	1 x	1 x	1 x	1 x	1 x
315	200	200	200	200	200	200	200	200	200	200

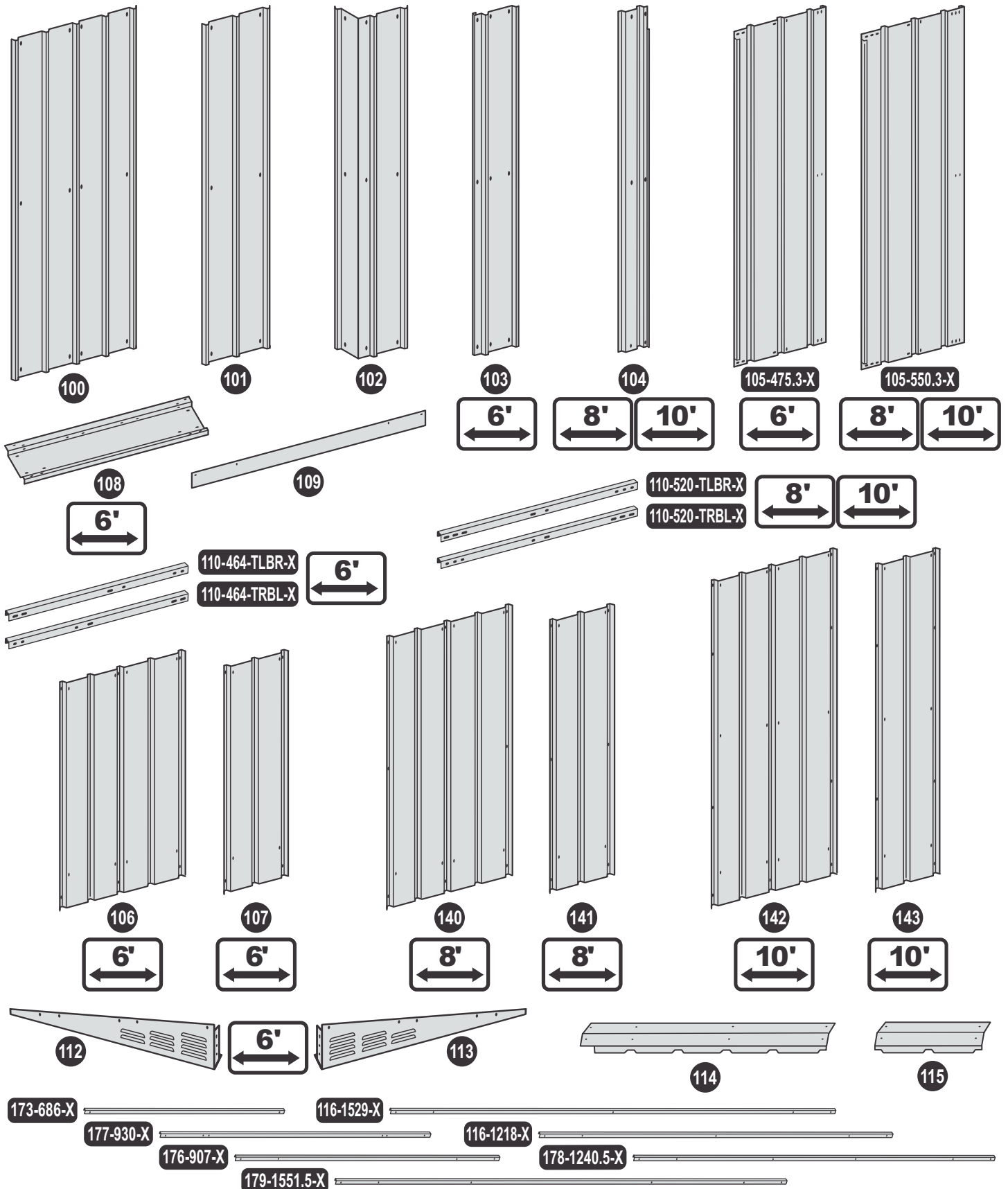

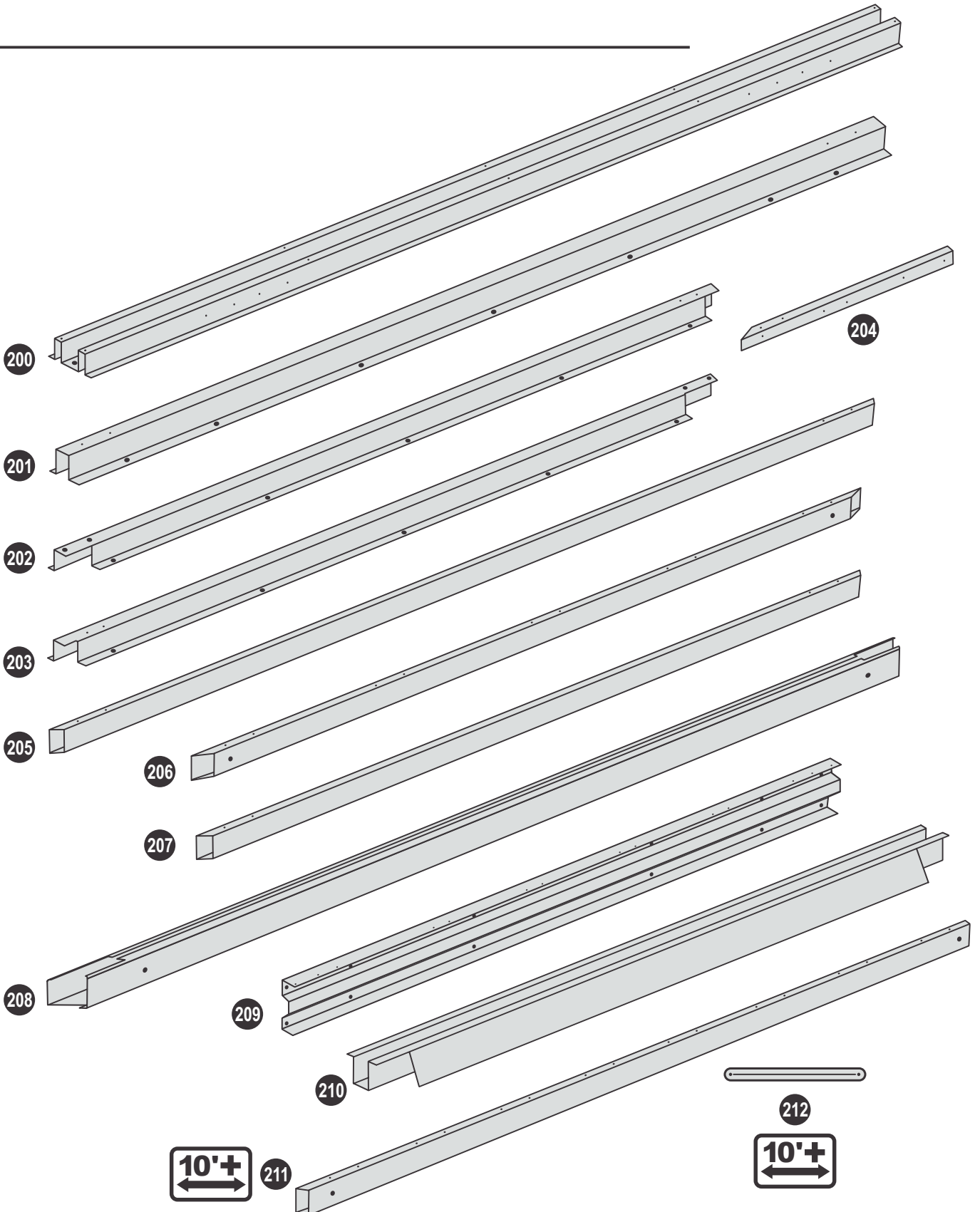

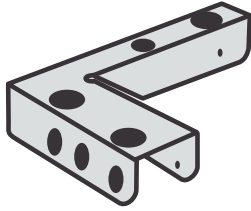

300

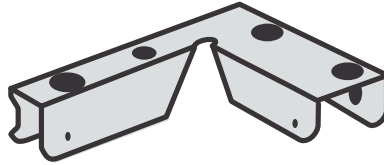

301

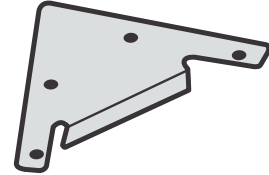

302



303

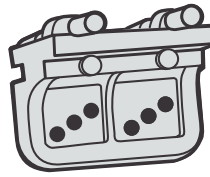

304



305

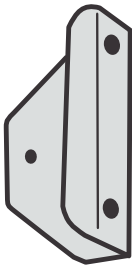

306



307

308

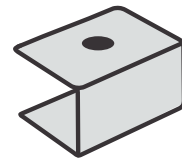

309



310

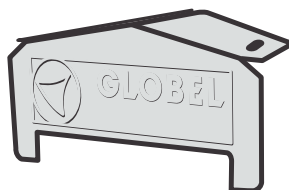

311



312



313



314

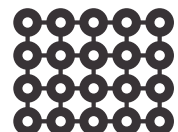

315

1

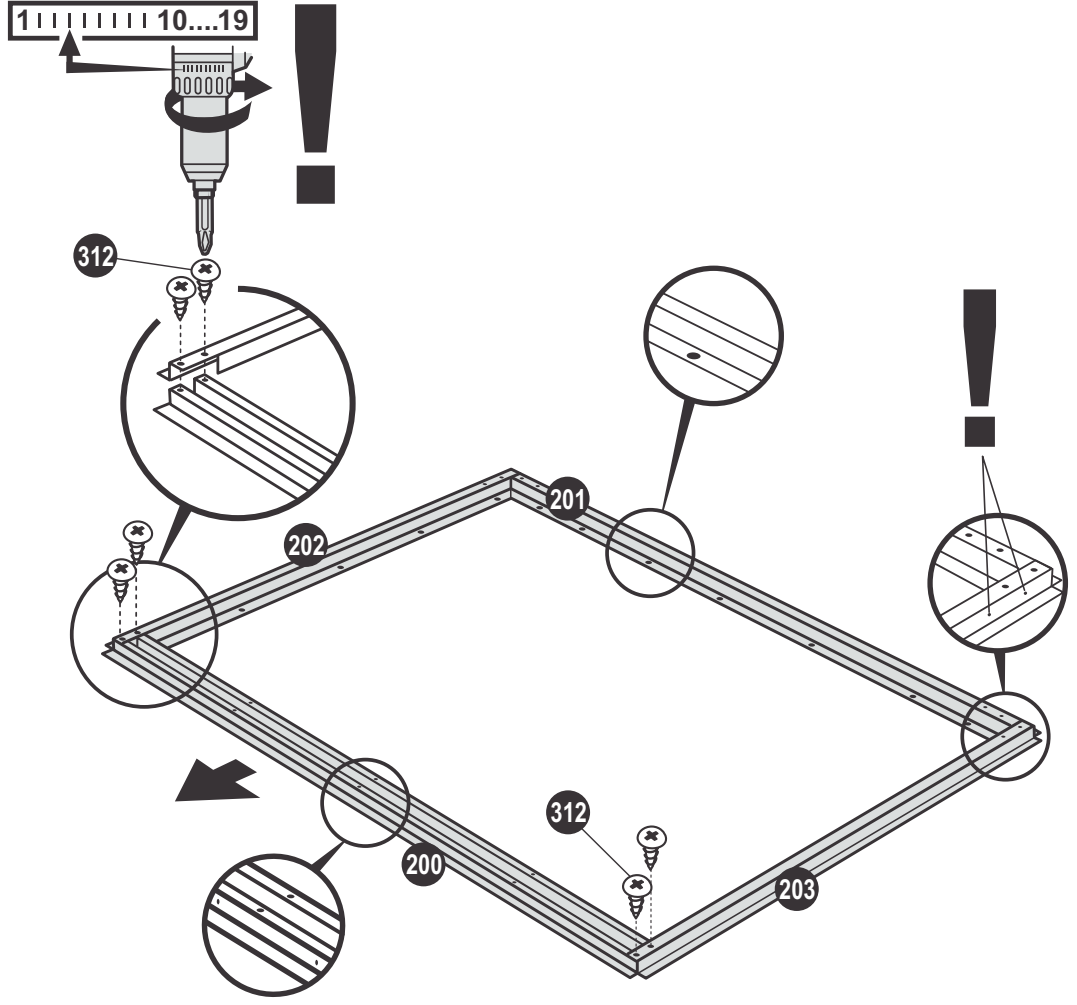
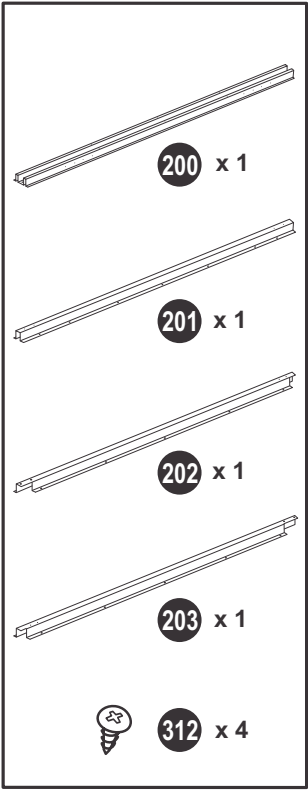

2

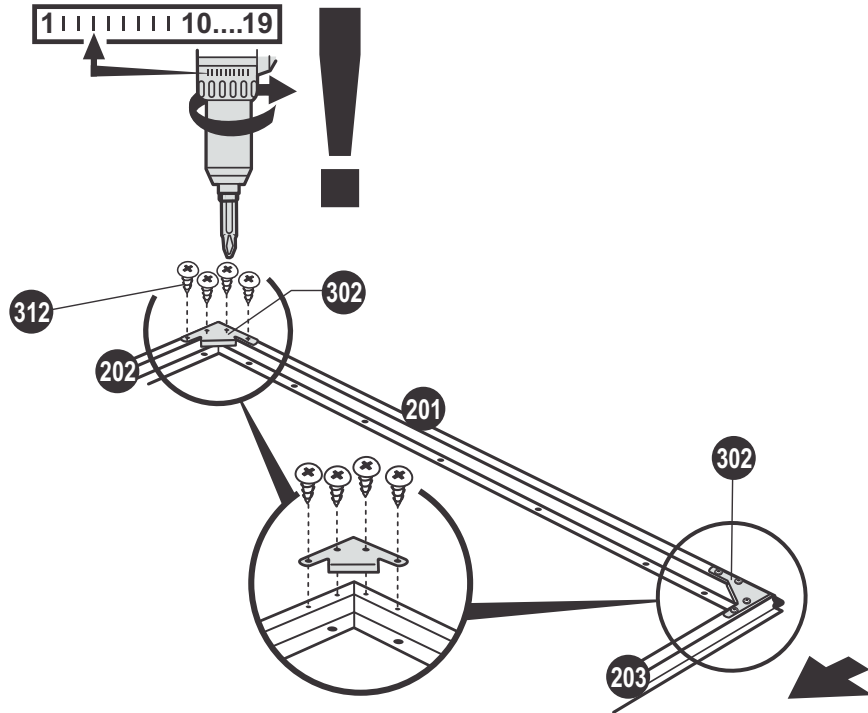
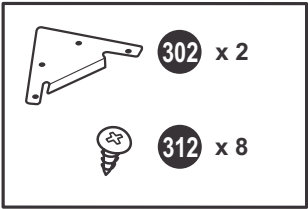

3

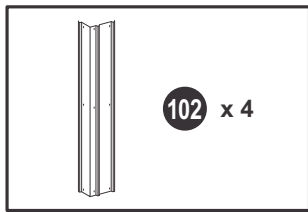

1



2

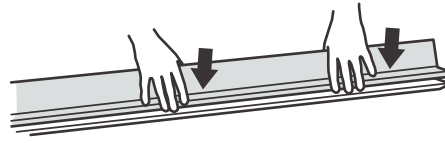

3

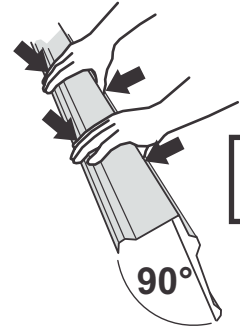

GB Lay panel on non-scratch surface and carefully form angle of 90 degrees by slowly working from the centre outwards along panel and bending it as you go. Do not over bend panel.

SK Panel položte na hladký povrch a opatrně vytvořte 90° uhol pomalým vypracováním zo stredy smerom von pozdĺž panelu a počas toho ho ohýbajte. Panel príliš neprehýnať.

HU Tegye a panelt olyan felületre, amelyik nem karcos és óvatosan alakítsa egy 90 fokos szöget középről lassan kifelé haladva a panel mentén és azt hajlítva ahogy halad. Ne hajlítson a panel fölé.

CZ Položte panel na neškrabavý povrch a pečlivě vytvořte úhel 90 stupňů tak, že budete pomalu a pracovat ze středu ven po panelu a ohýbat ho jak budete pokračovat. Neohněte panel přespříliš.

PL Połóż panel na niepodatnej na porysowanie powierzchni i ostrożnie utwórz kąt 90, powoli pracując od środka ku brzegom wzdłuż panelu, zginając go stopniowo. Nie przegnij panelu.

4

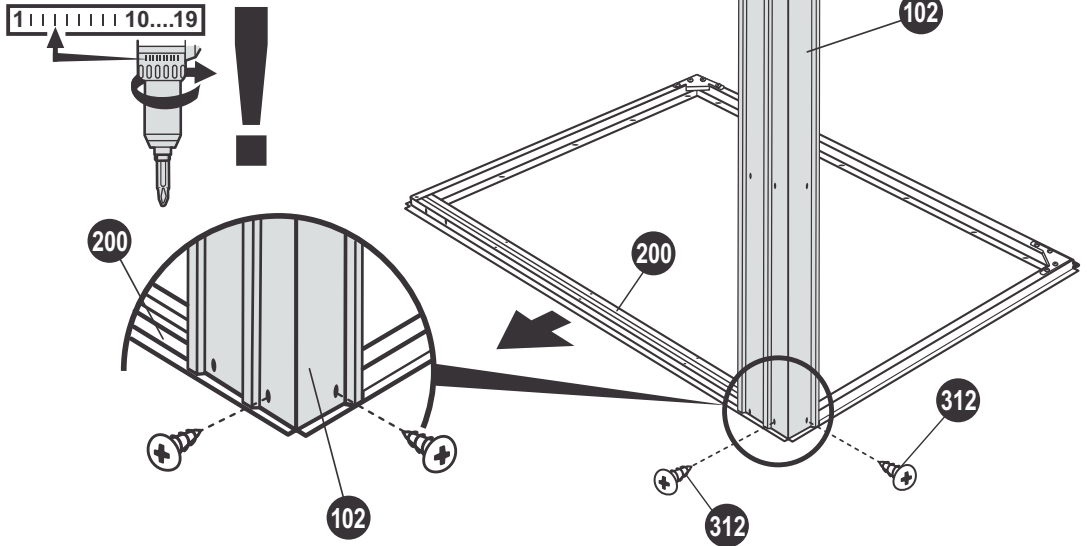
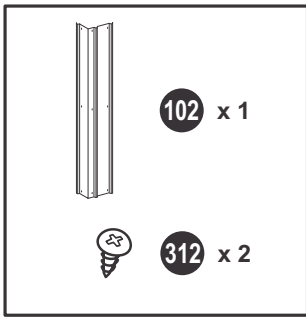

5

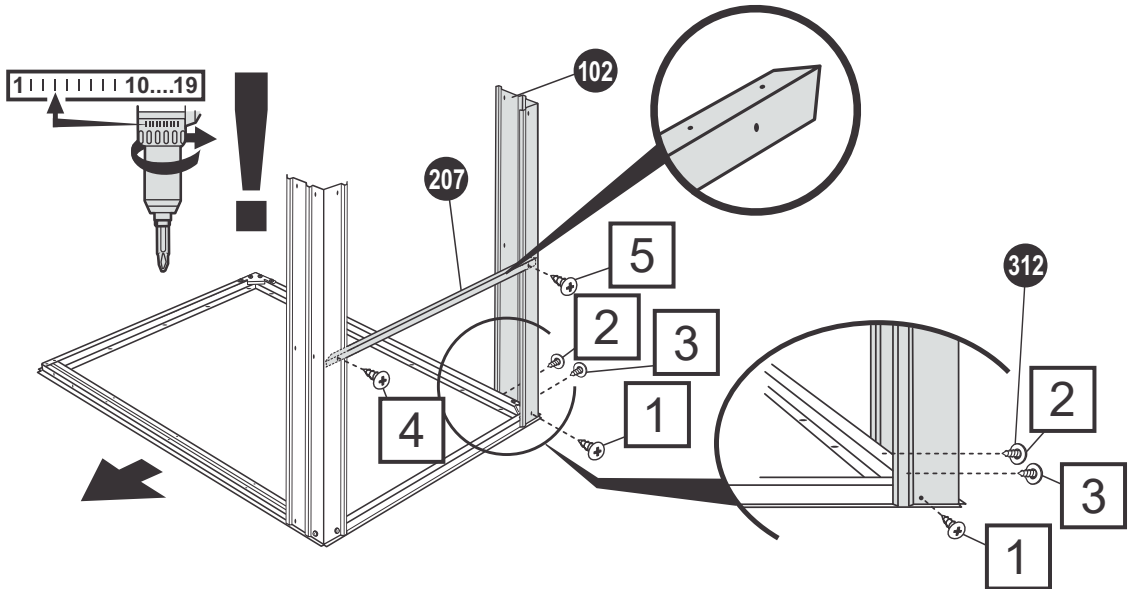
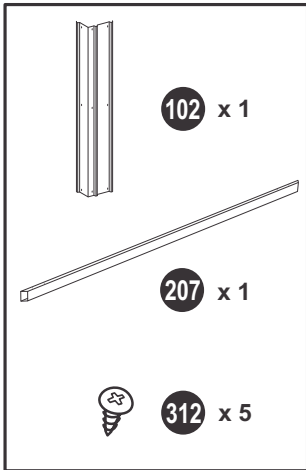

6

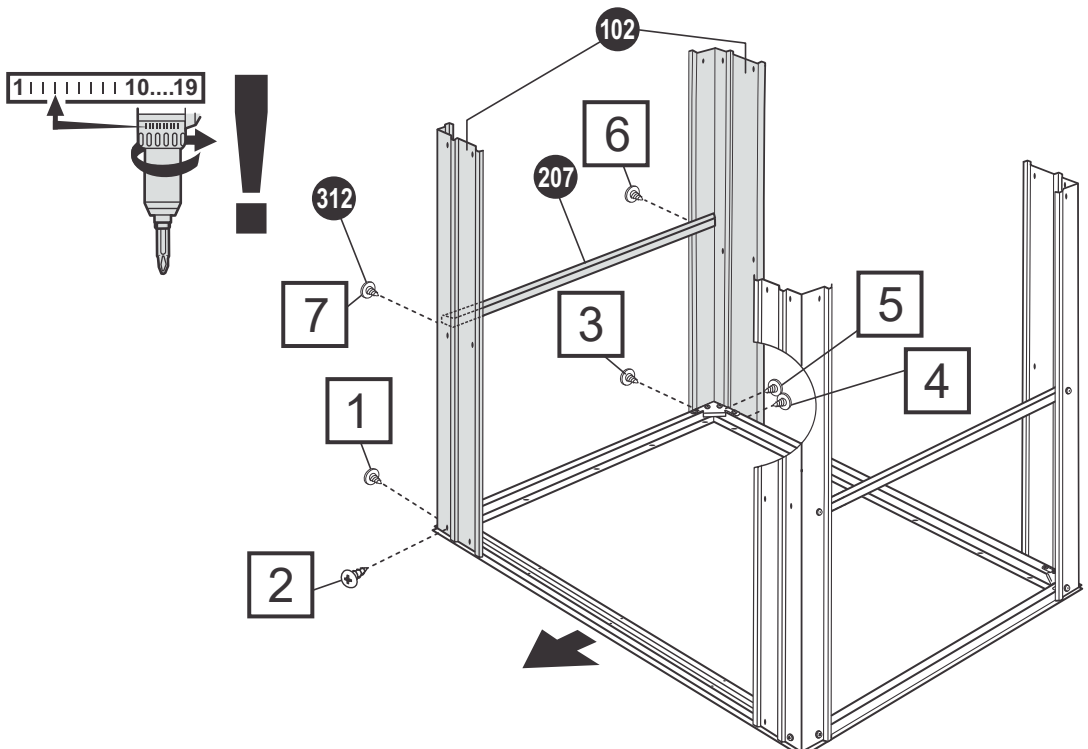
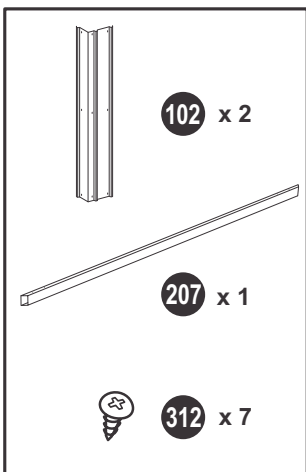

7

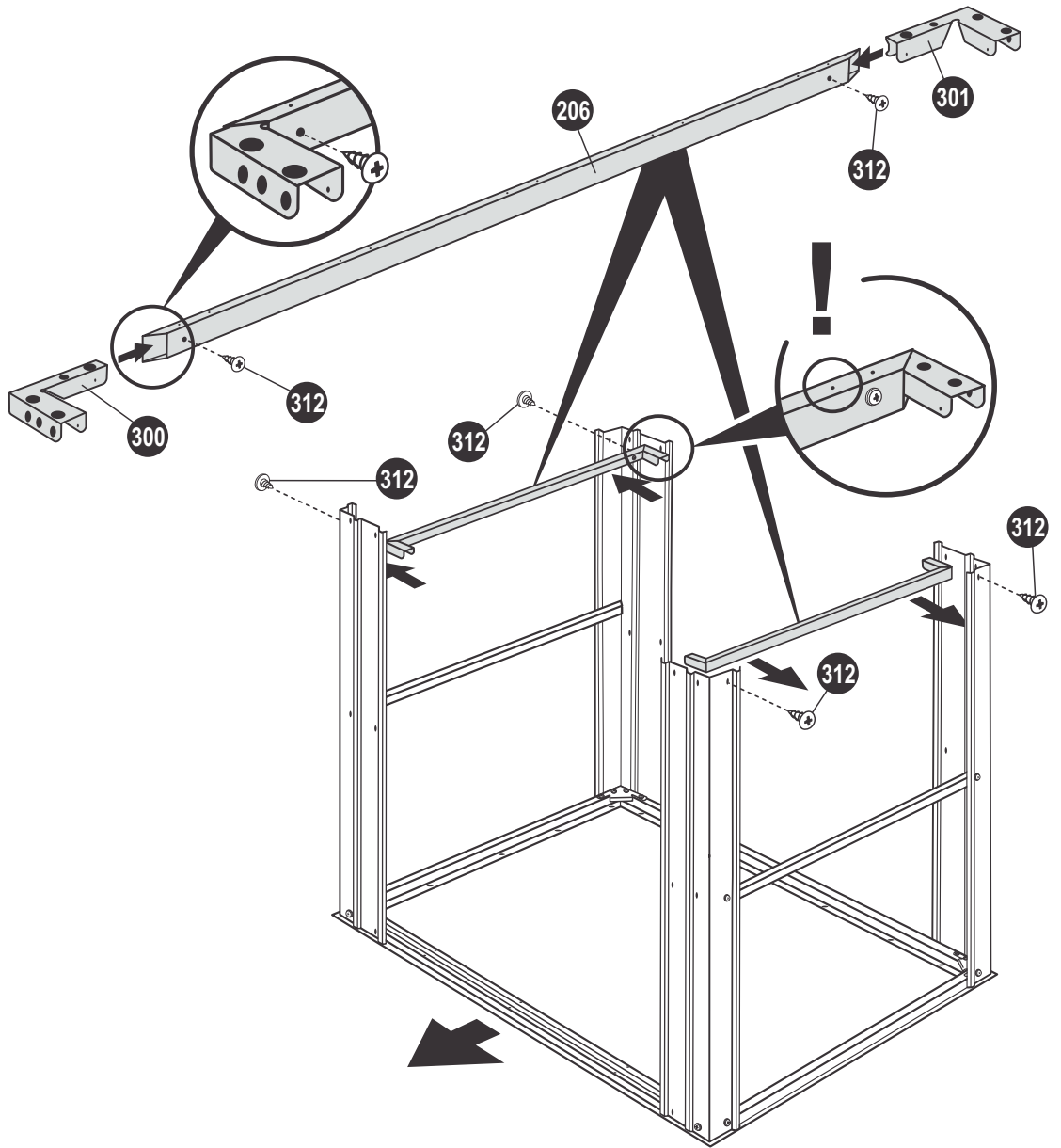
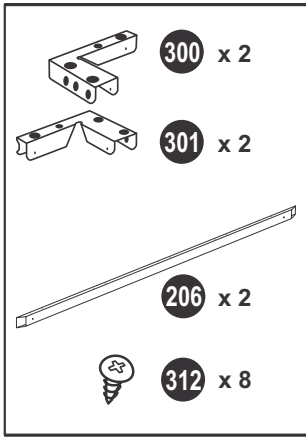

8

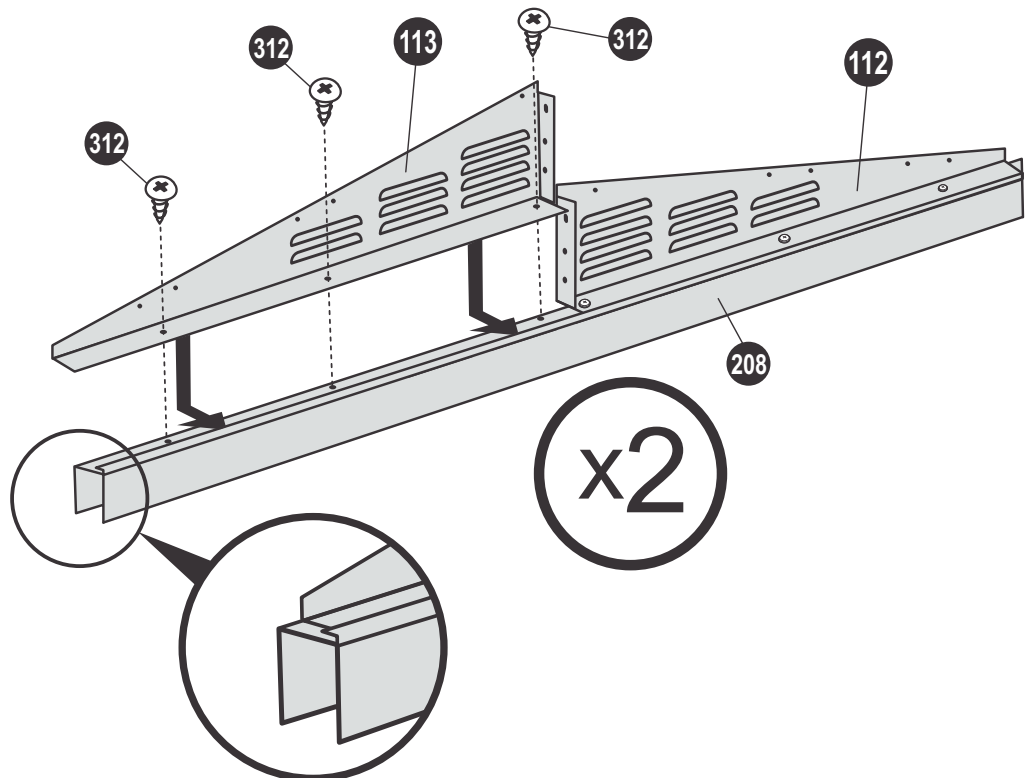
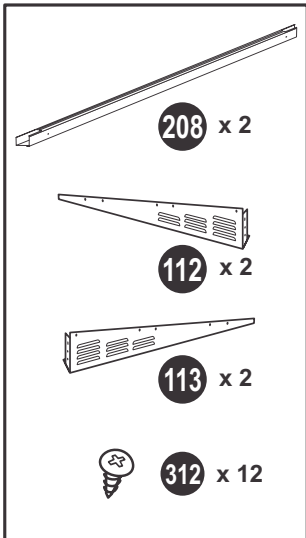

9

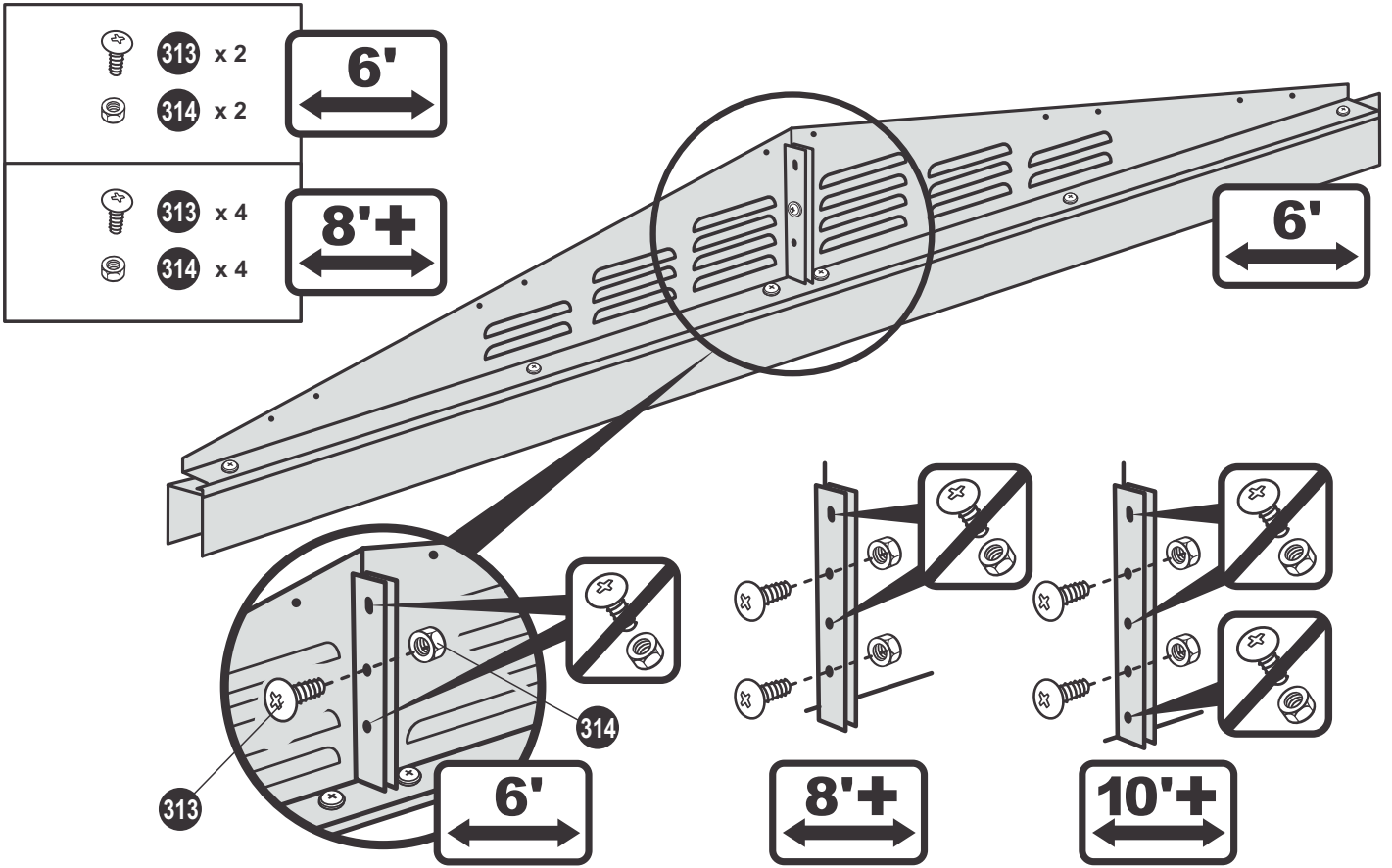

10

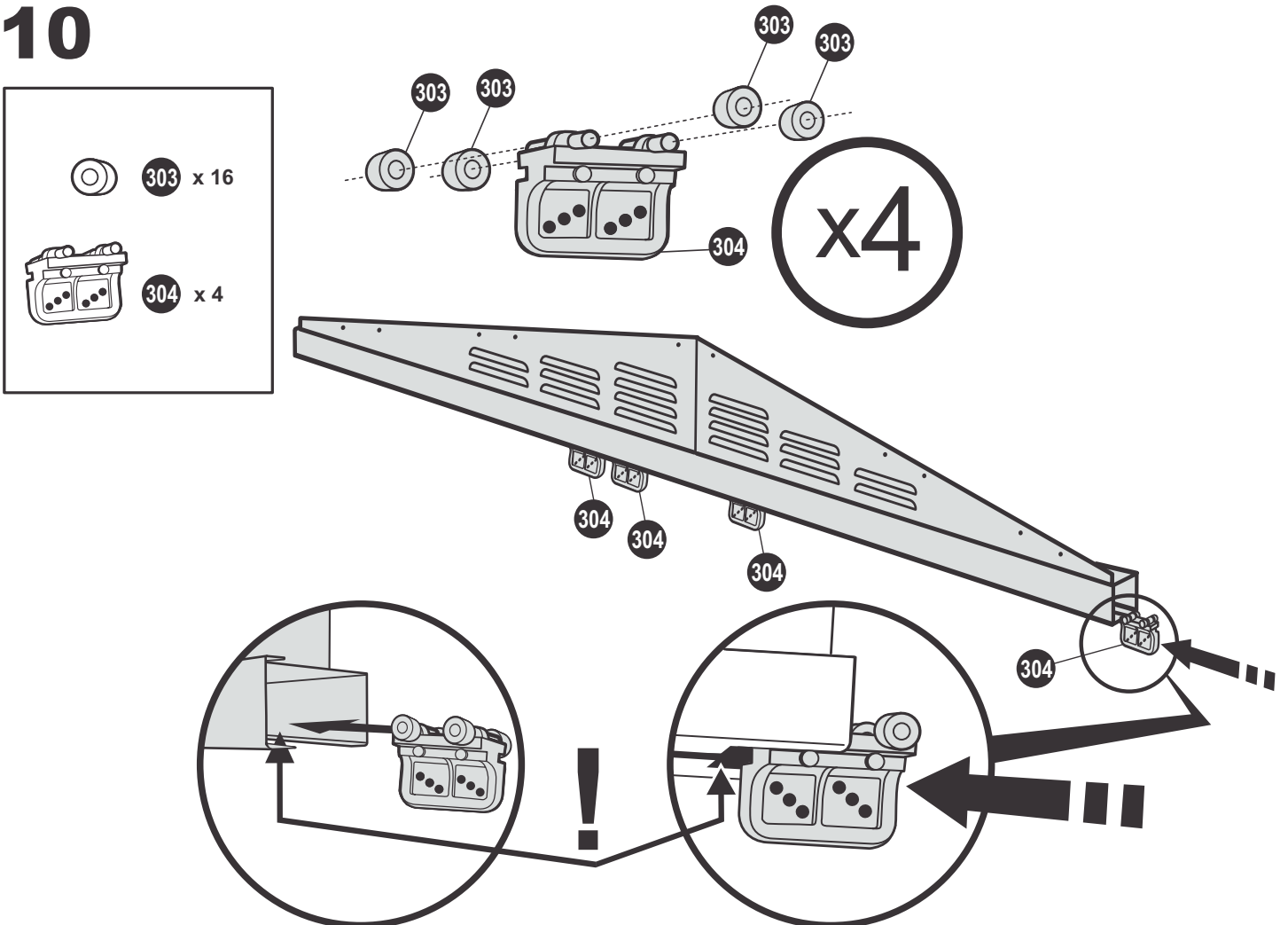

11

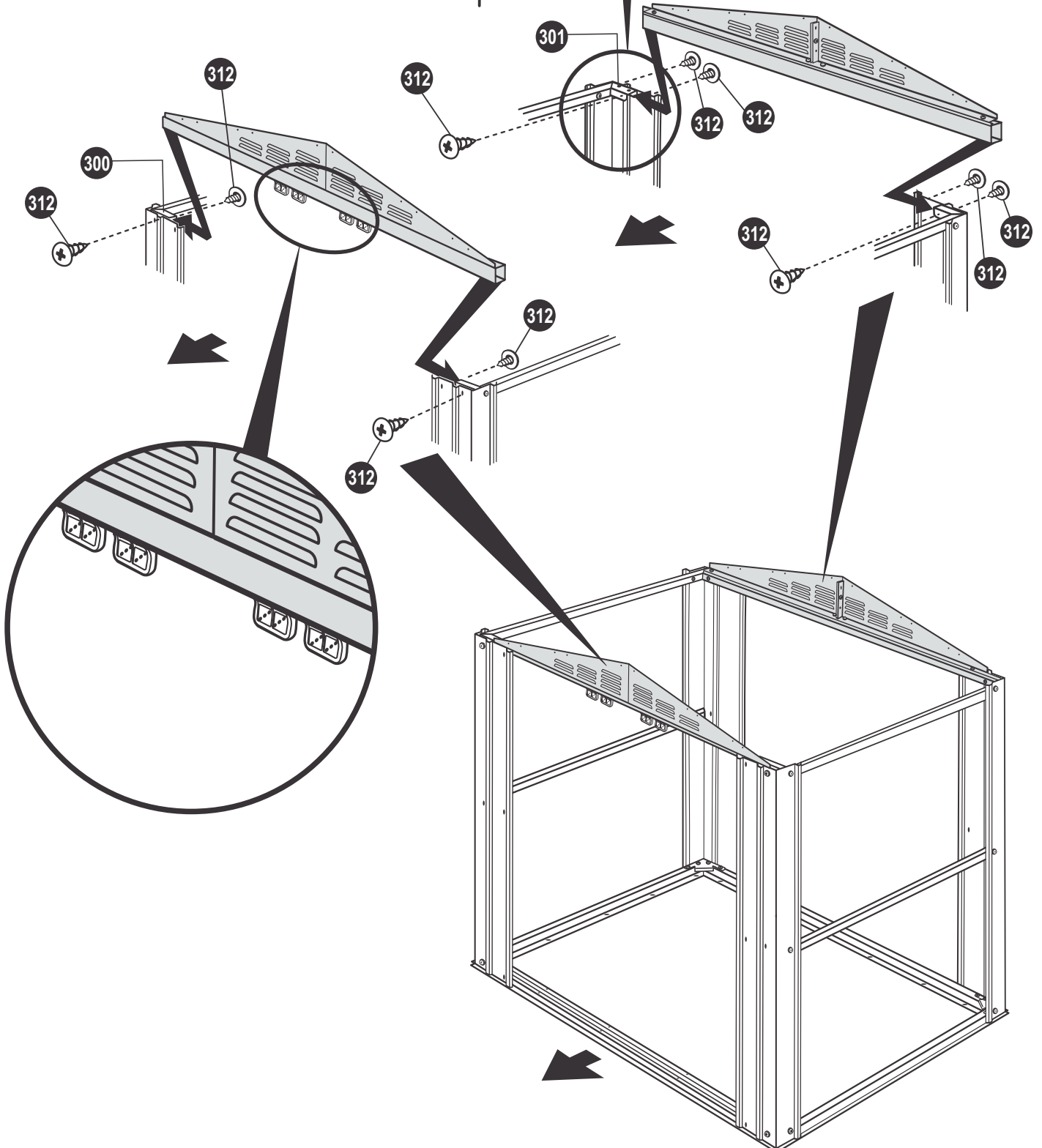
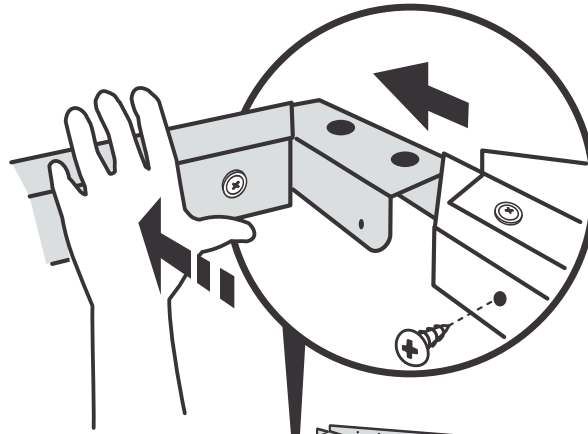
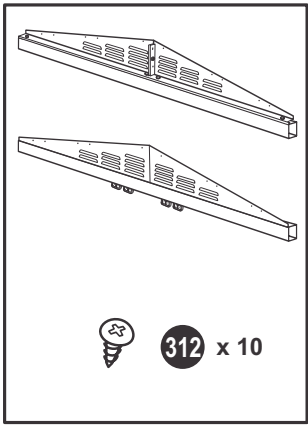

12

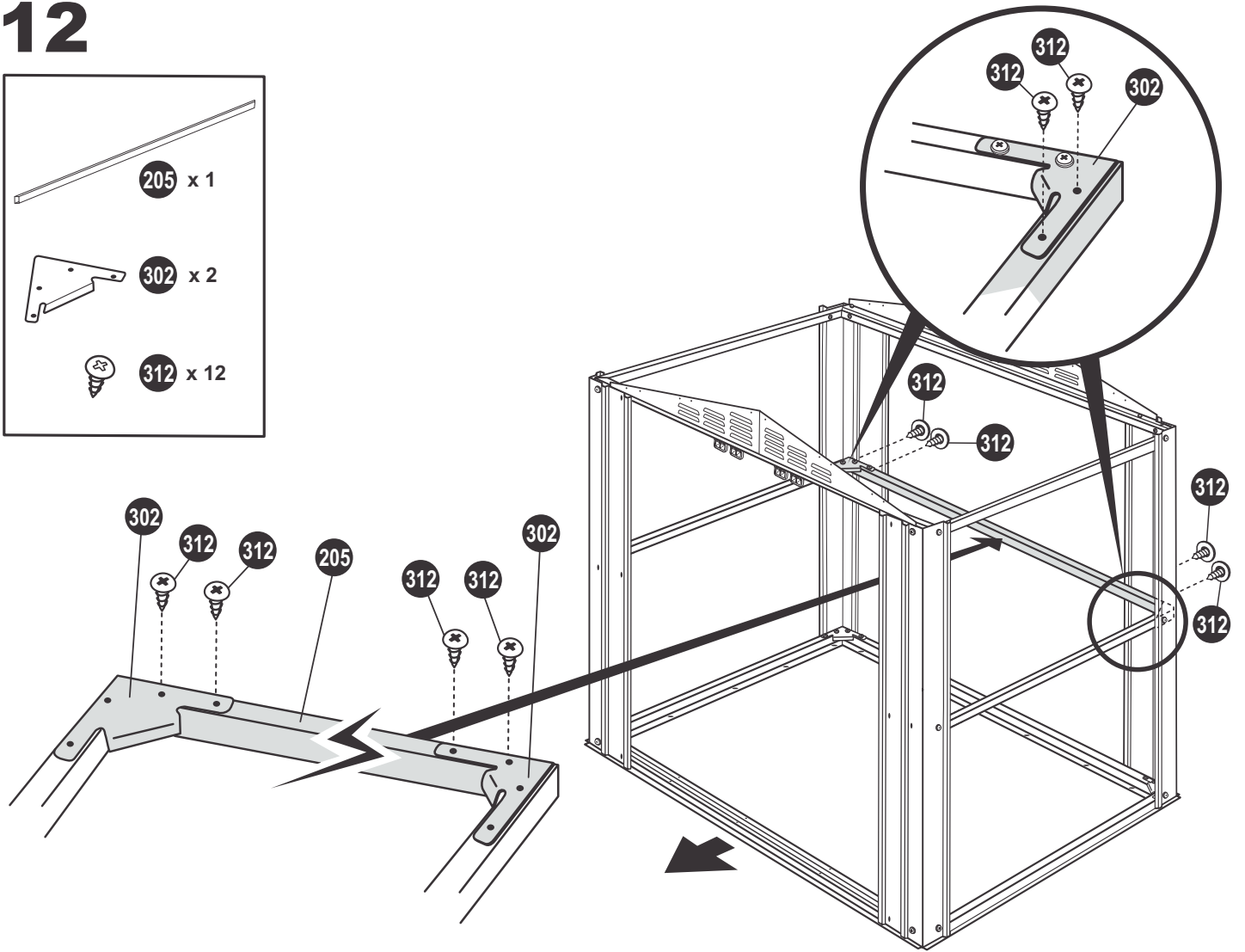
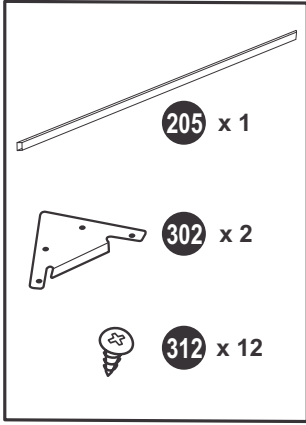

13

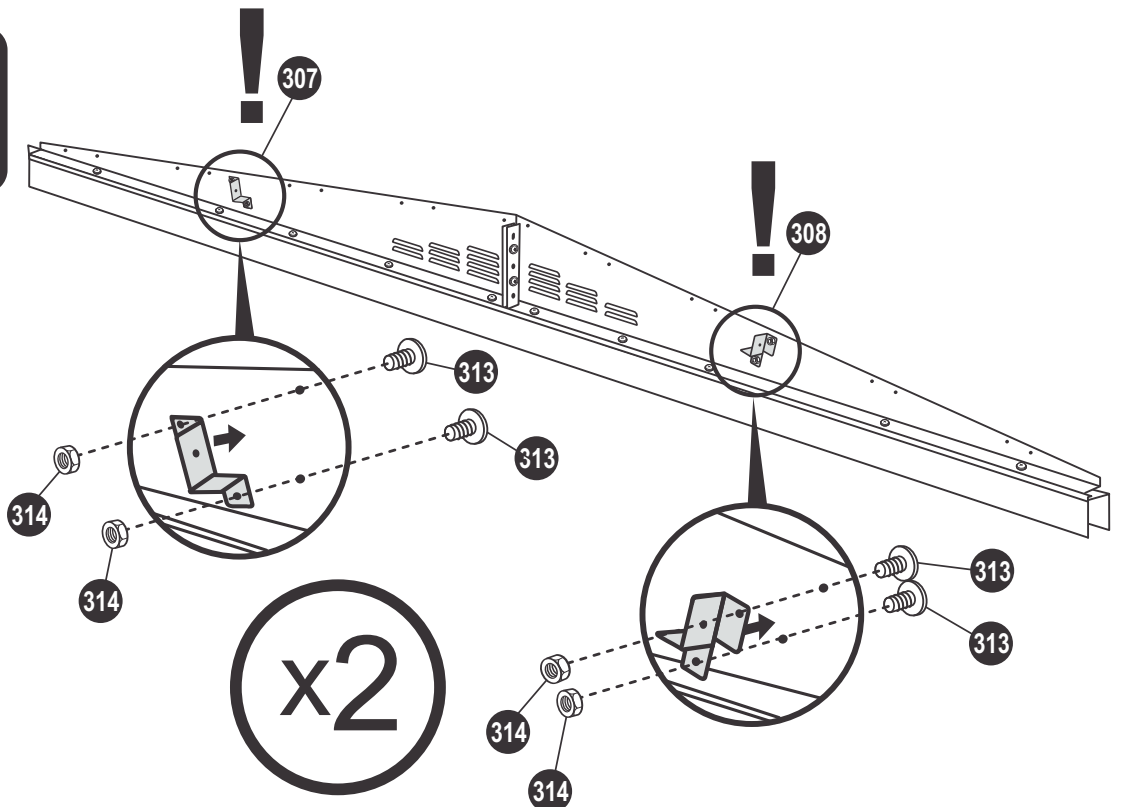
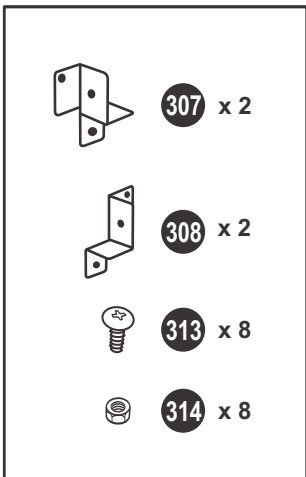
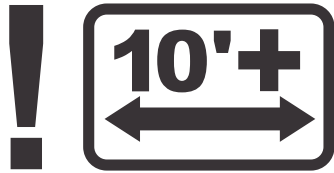

14

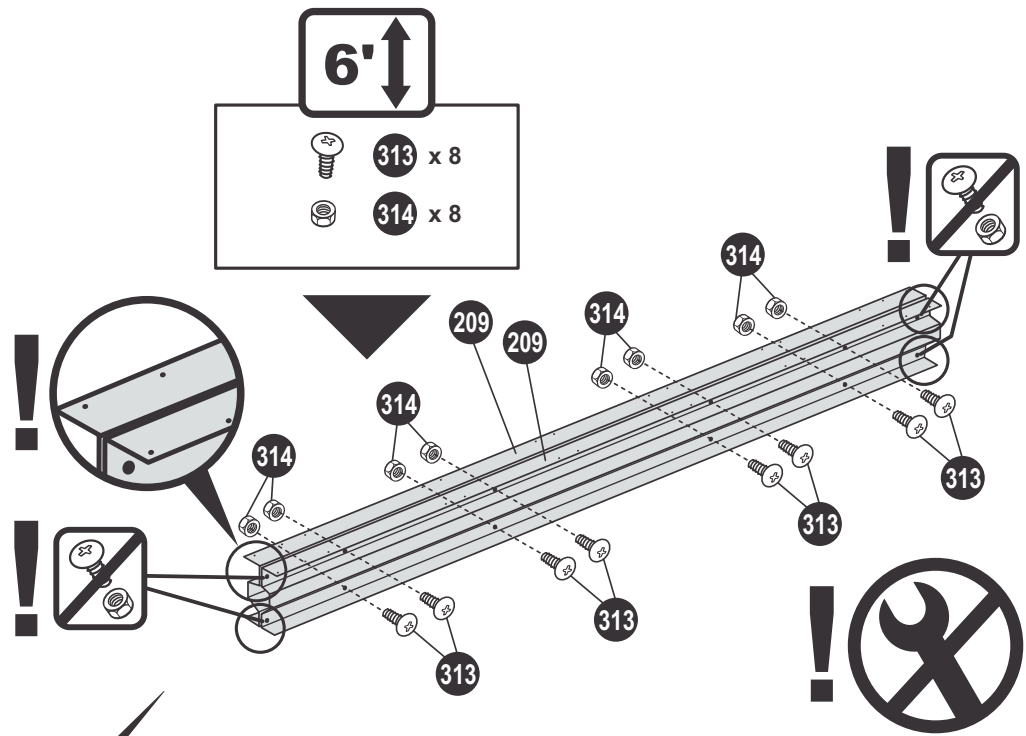
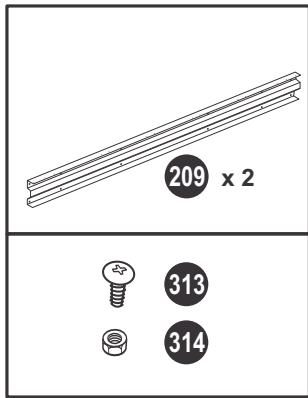

15

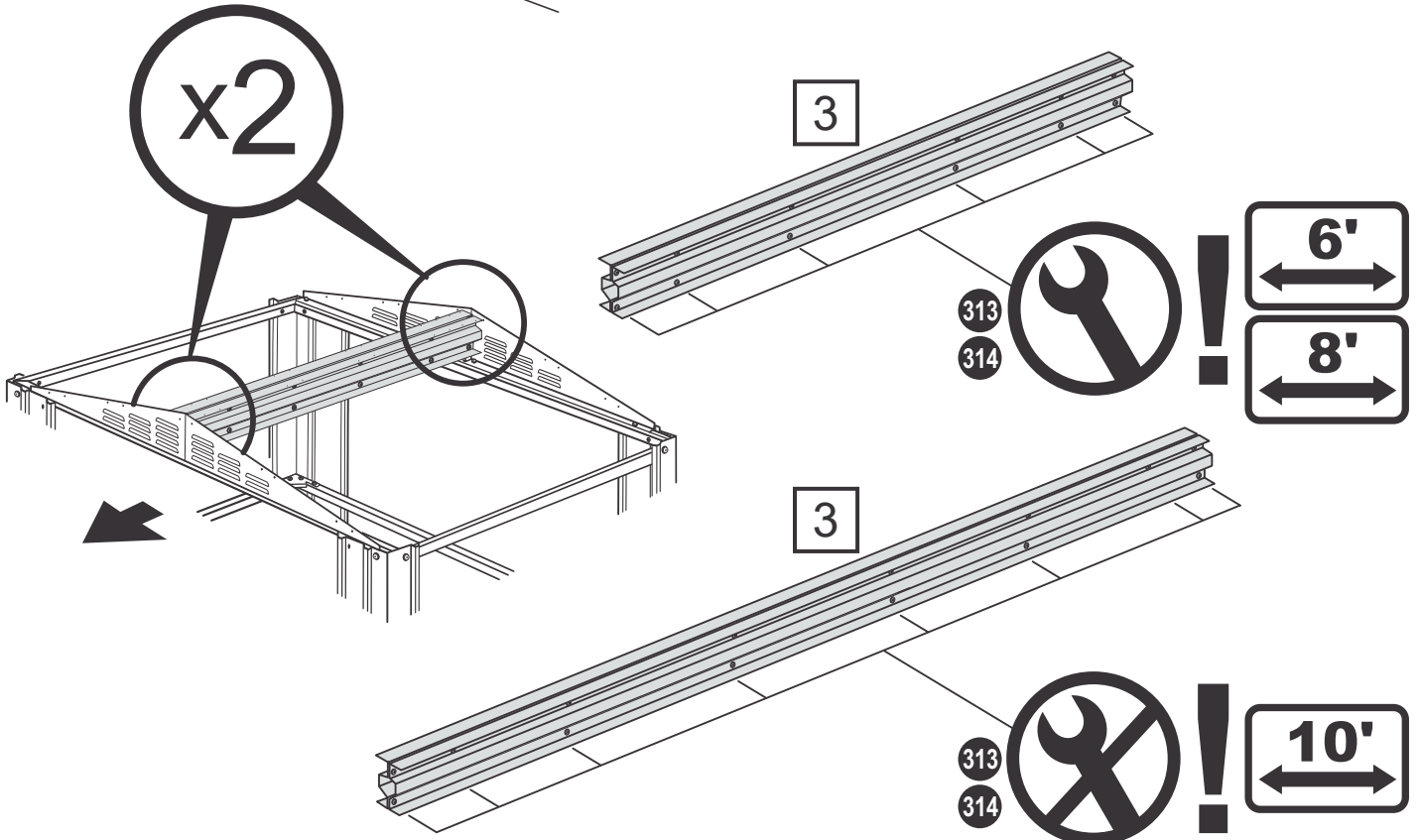
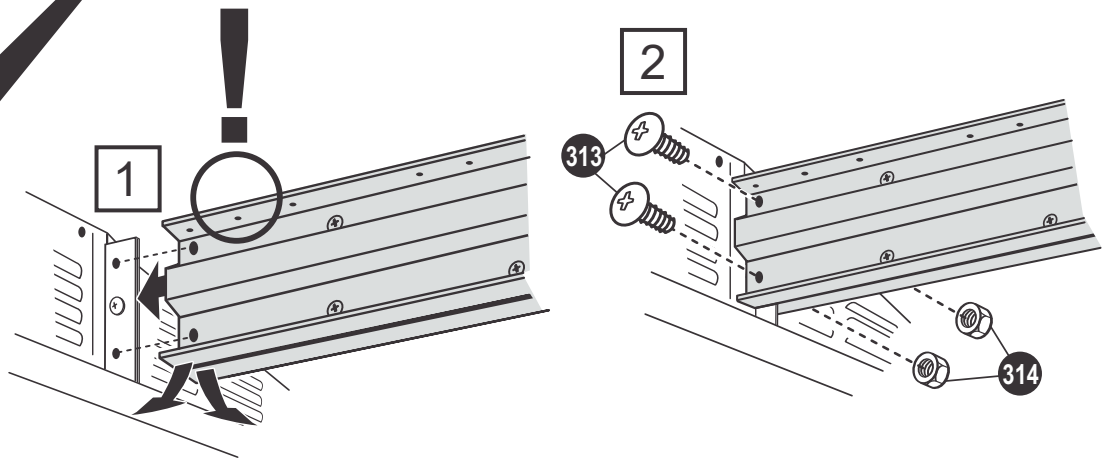
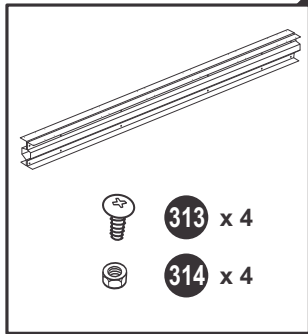

16

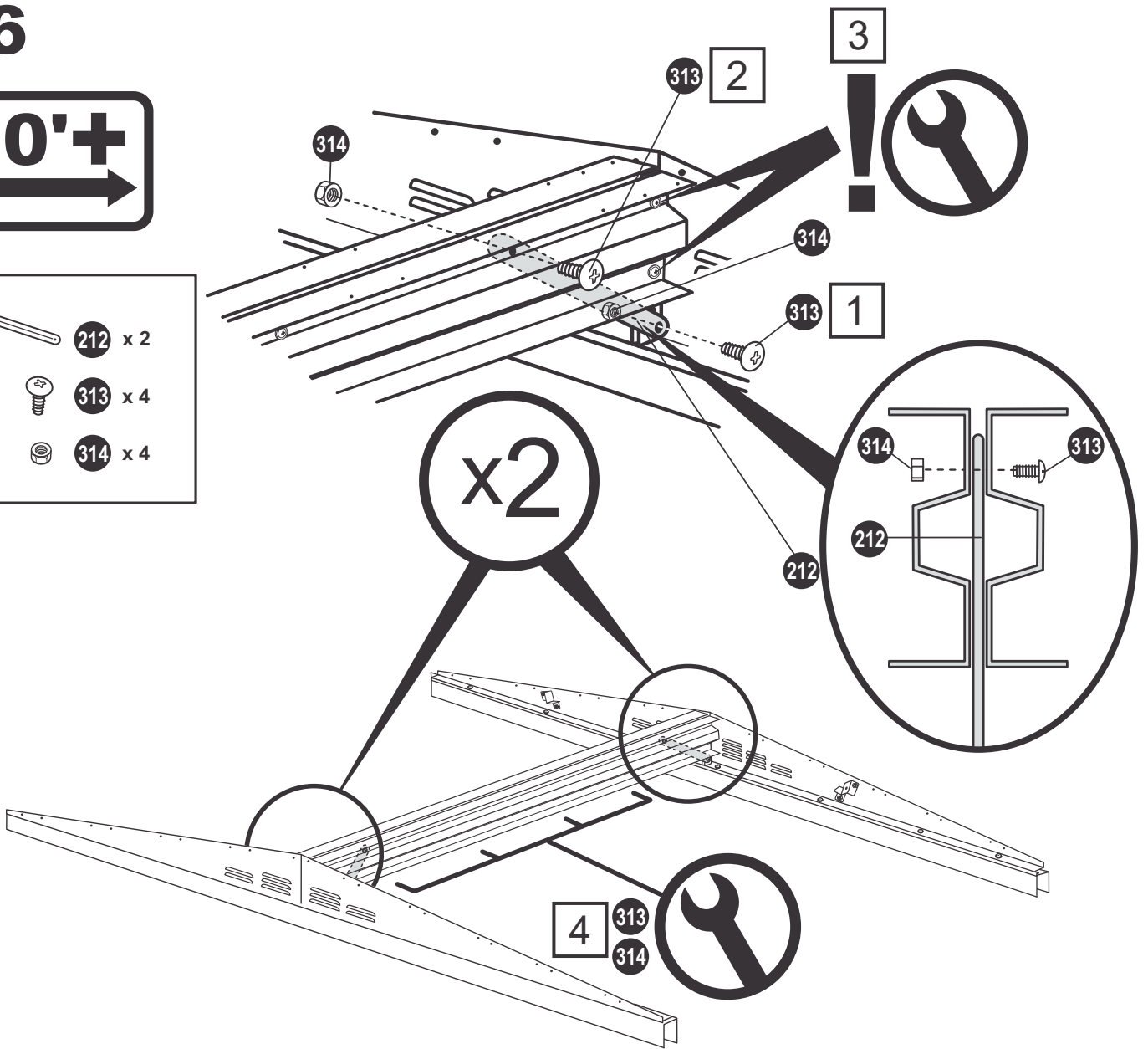
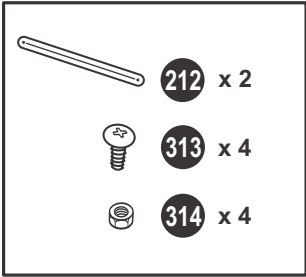
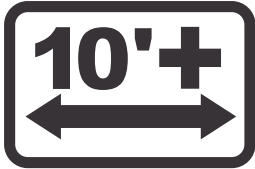

17

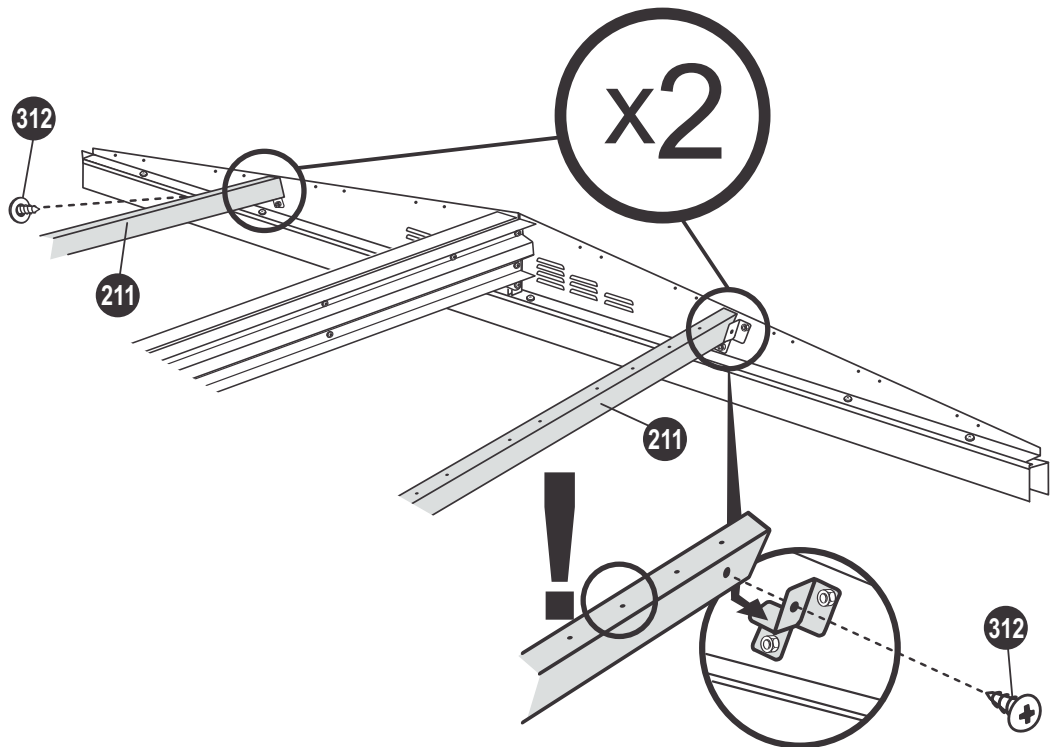
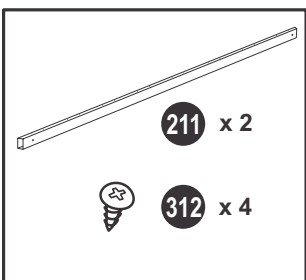

GB SIDE WALL SHEET CONFIGURATIONS

SK ZOSTAVY PLECHU BOČNEJ STENY

HU OLDAL FALLAP ALAKZATOK

CZ KONFIGURACE POSTRANNÍHO PANELU

PL KONFIGURACJE BLACHY ŚCIANY BOCZNEJ

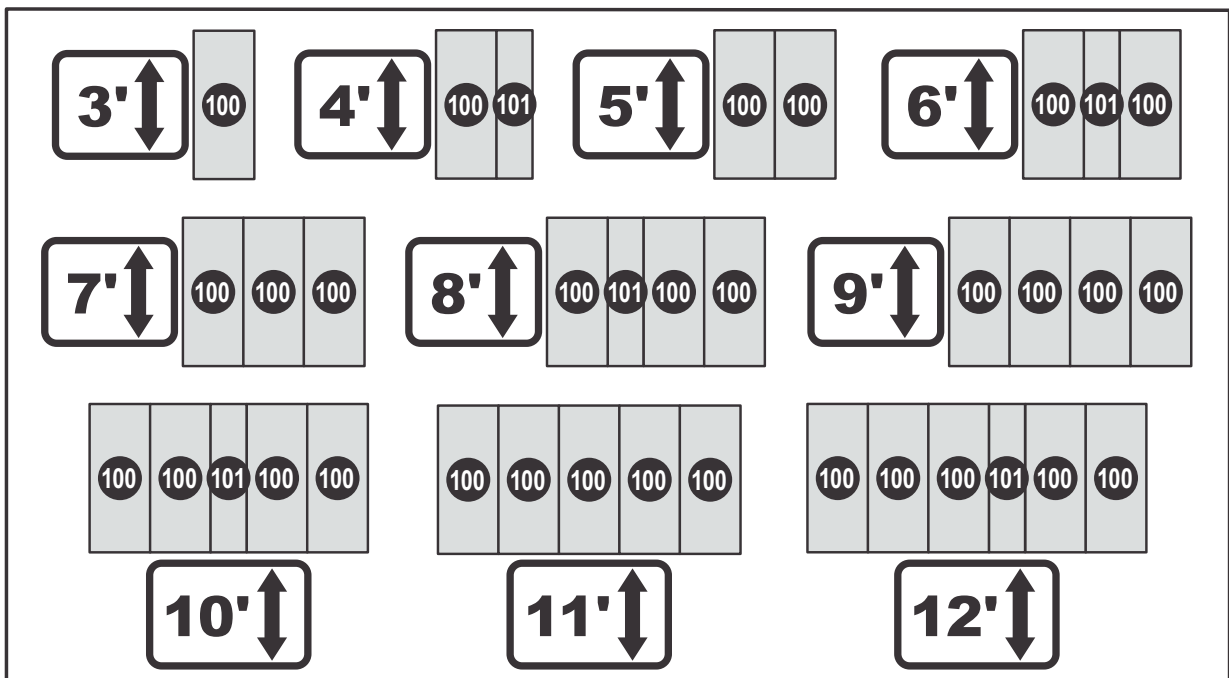

POŘADÍ ŠROUBŮ

KOLEJNOŠĆ MOCOWAŃ ŚRUB

PORADIE SKRUTIEK

CSAVARKELLÉKEK RENDJE

GB ORDER OF SCREW FIX

CZ POŘADÍ ŠROUBŮ

SK PORADIE SKRUTIEK

PL KOLEJNOŠĆ MOCOWAŃ ŚRUB

HU CSAVARKELLÉKEK RENDJE

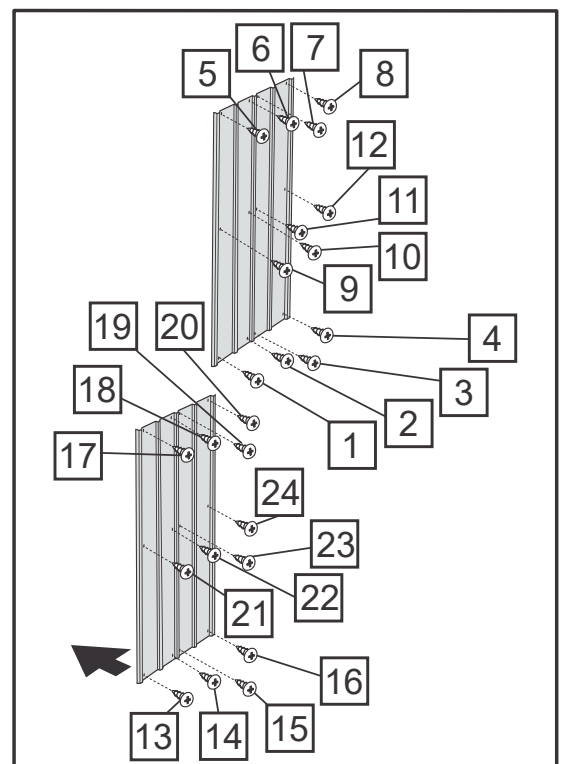

(GB) IF YOUR SHED INCLUDES WINDOW, FOLLOW INSTRUCTIONS SHOWN HERE. FROM STEP 18.

(SK) AK VÁŠ DOMČEK MÁ OKNO, RIADTE SA POKYNNI ZNÁZORNENÝMI TU. OD KROKU 18.

(HU) HA AZ ÖN SUFNIJÁN ABLAK VAN, AKKOR KÖVESSE AZ ITT JELZETT UTASÍTÁSOKAT. A 18. LÉPÉSTŐL

(CZ) JESTLIŽE VÁŠ DOMEK ZAHRNUJE OKNO, SLEDUJTE INSTRUKCE UVEDENÉ ZDE, OD BODU 18.

(PL) JEŚLI TWOJA SZOPA ZAWIERA OKNO, POSTĄP ZGONIE Z PRZEDSTAWIONYMI TU INSTRUKCJAMI. OD KROKU 18.

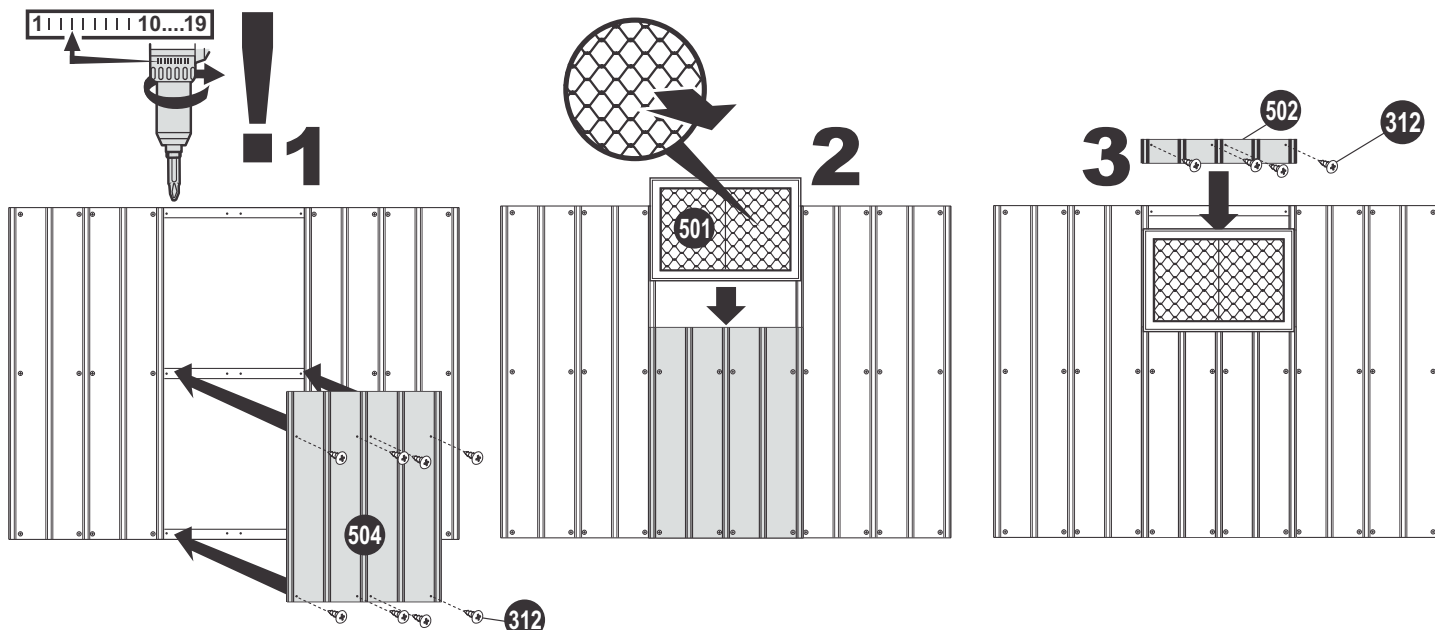
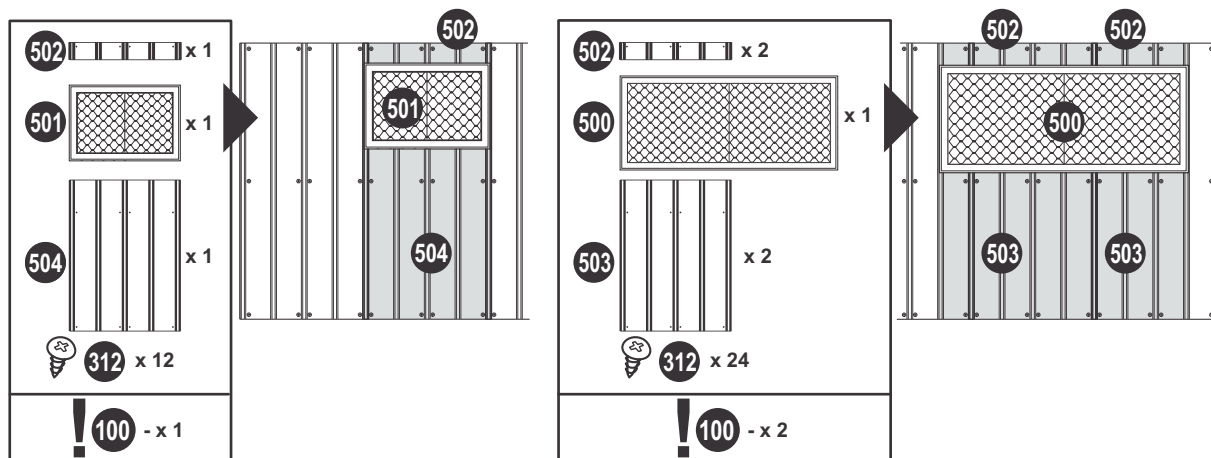

18

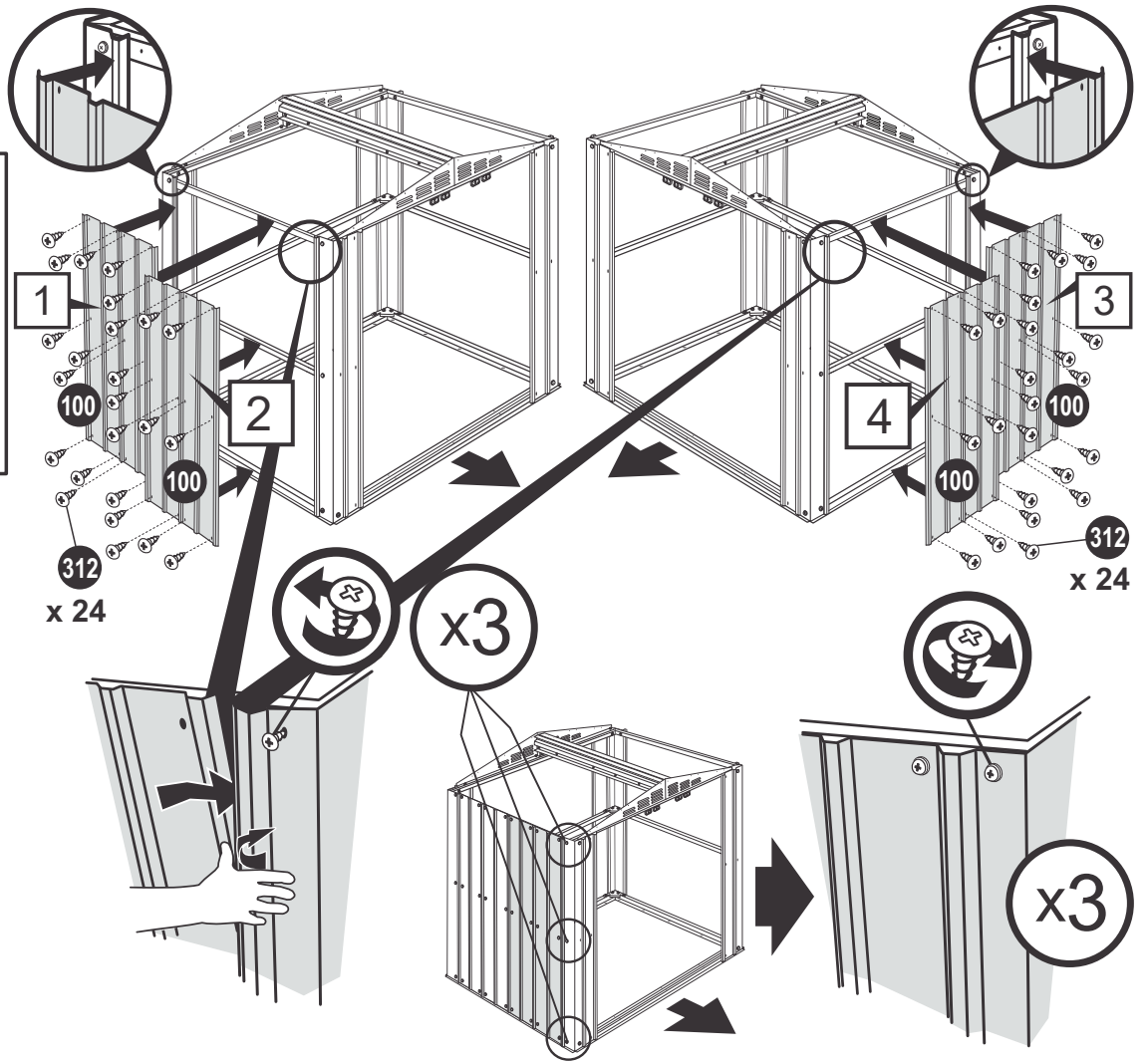
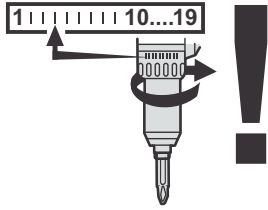
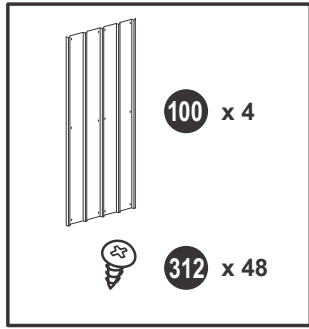

19

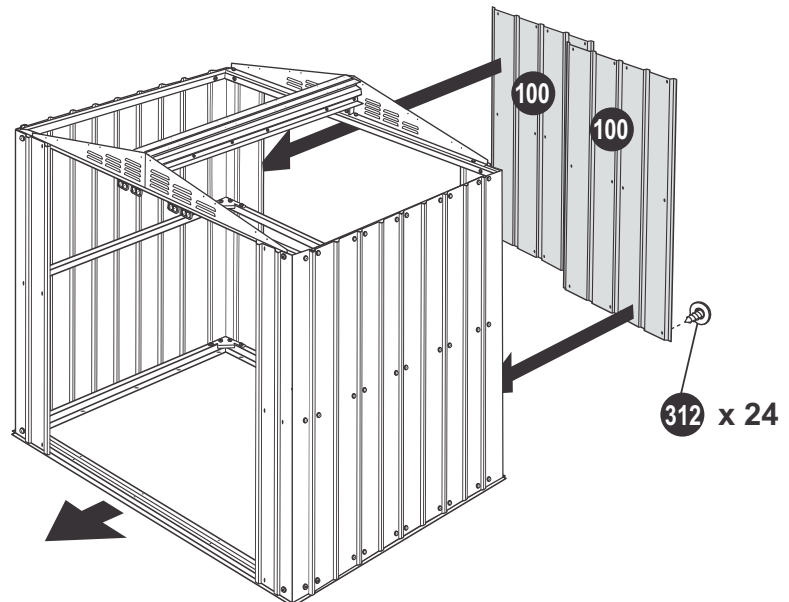
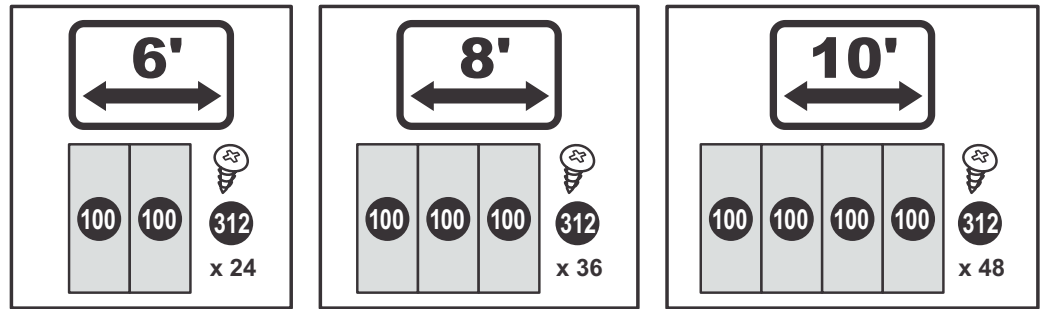
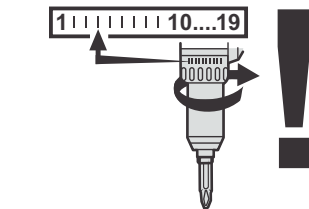
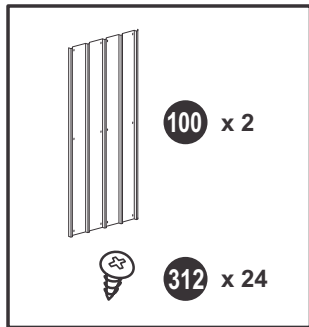

20

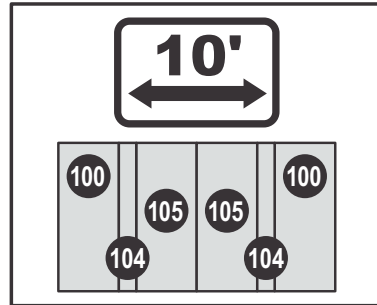
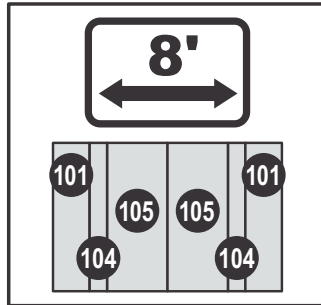
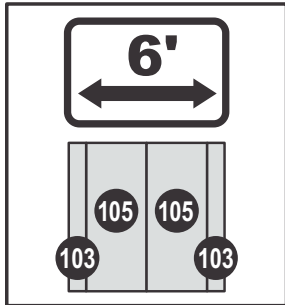
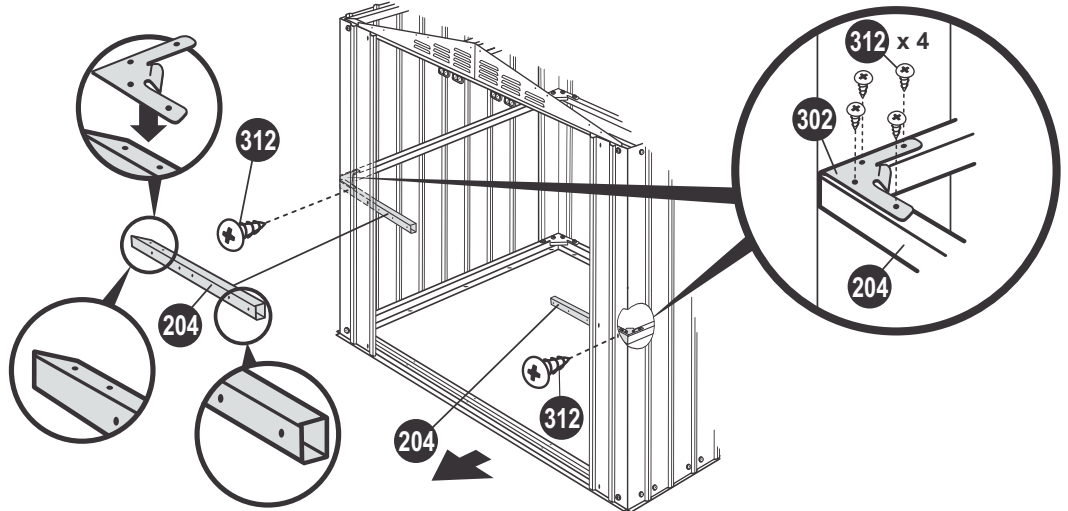
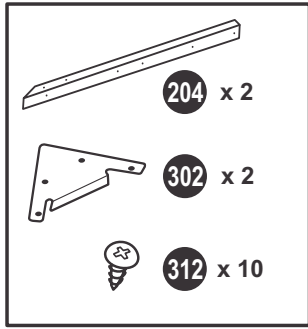

21

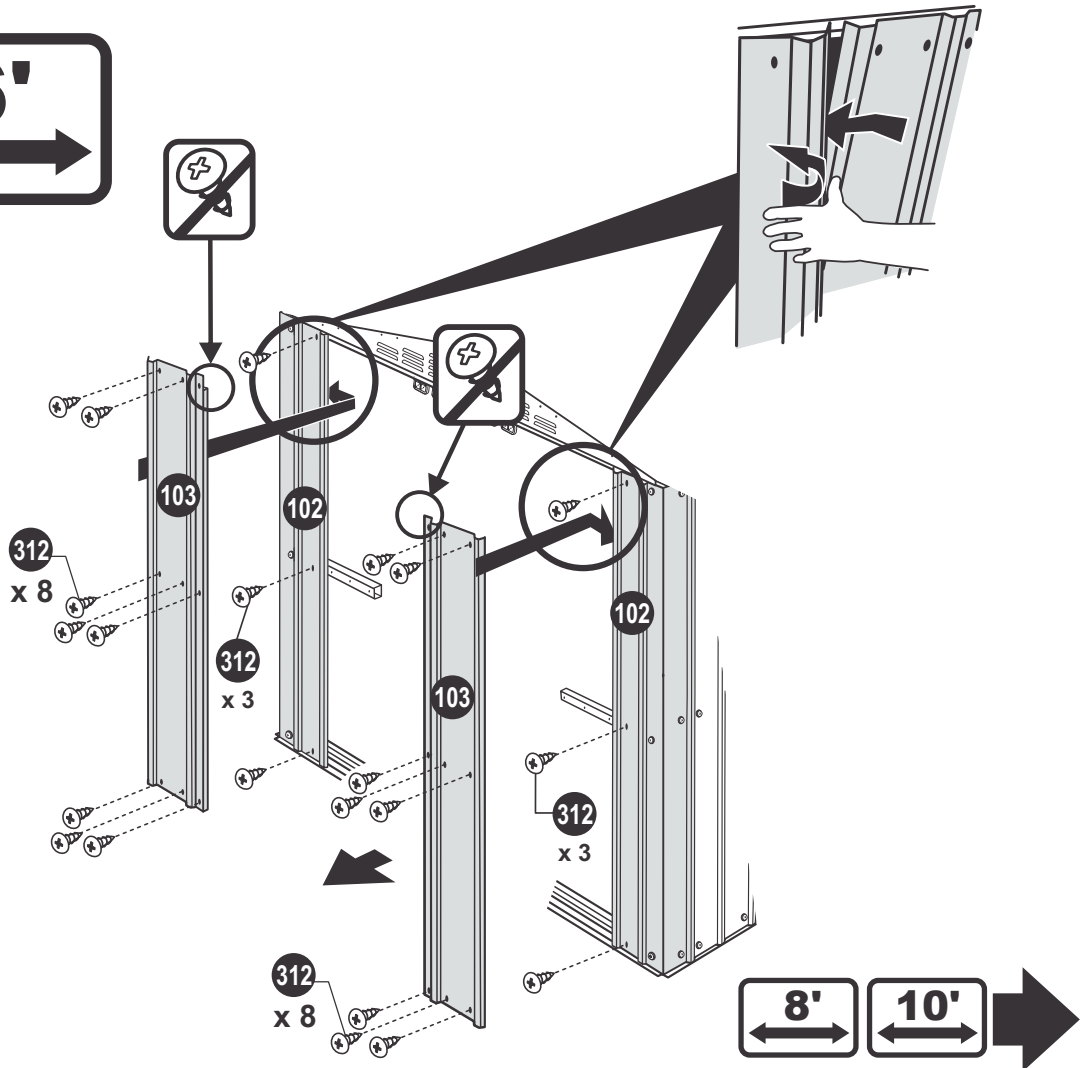
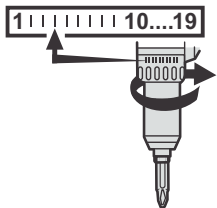
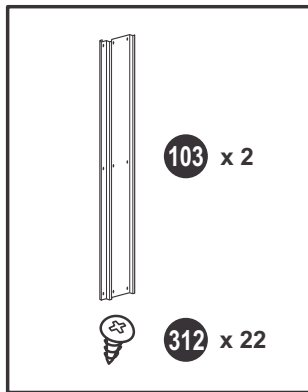

21...

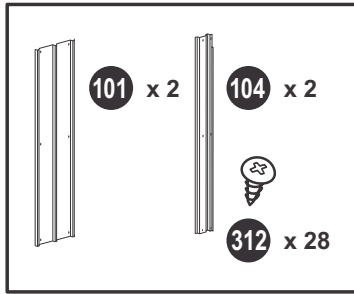

1 | 10...19

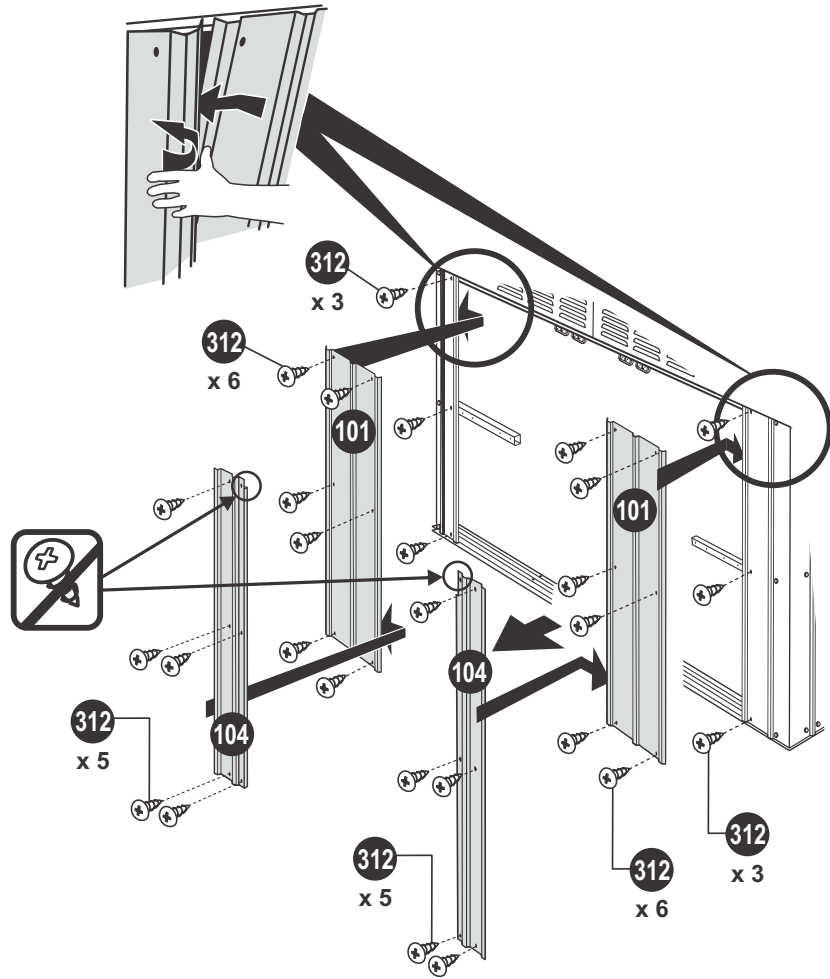

21...

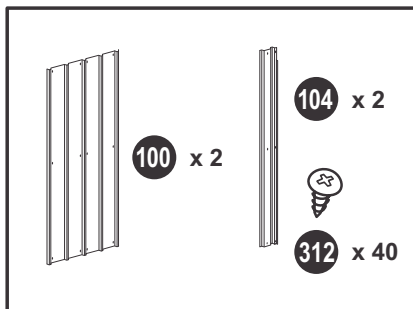
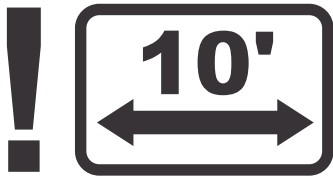

1 | 10...19

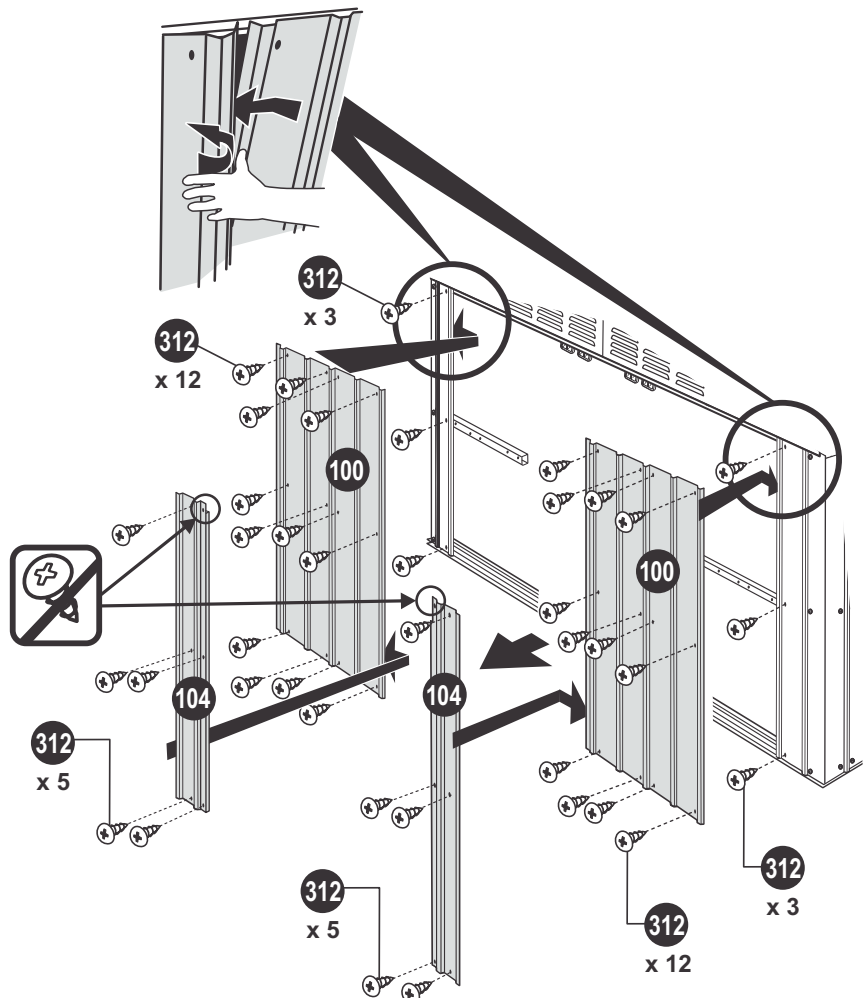

22

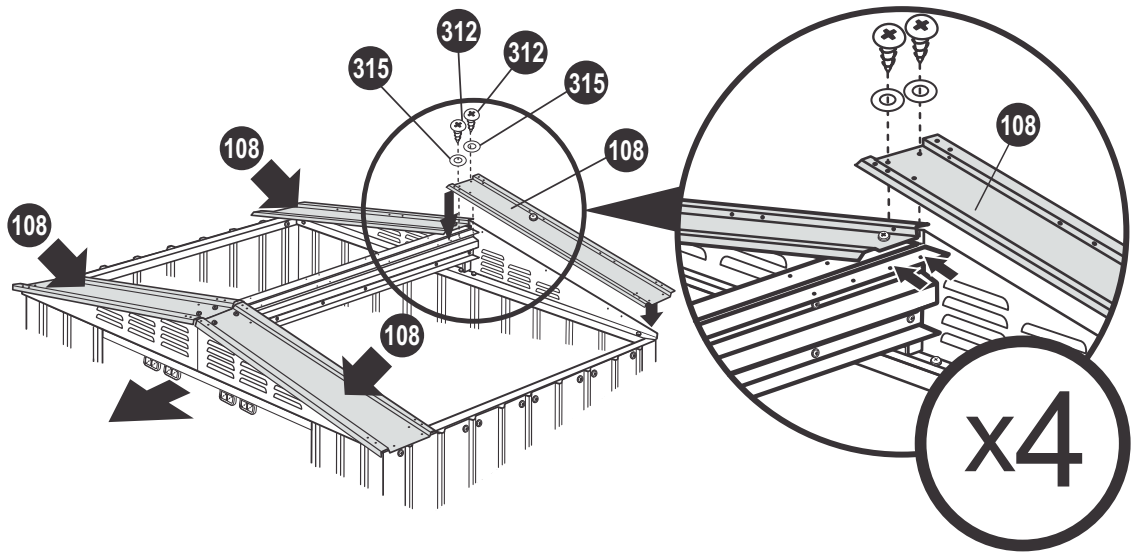
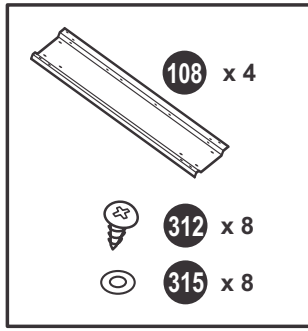

23

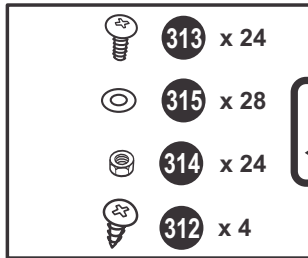

6'

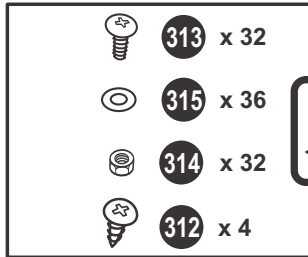
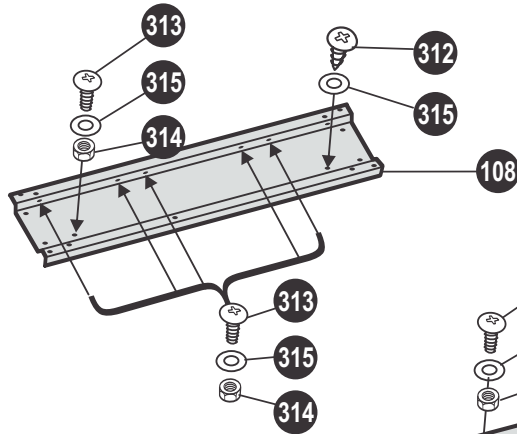

8'

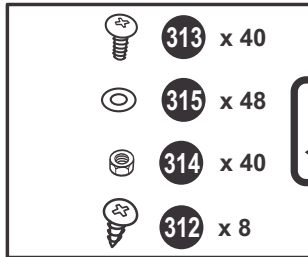
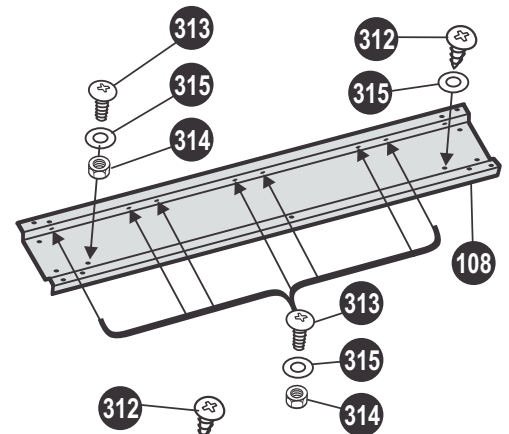

10'

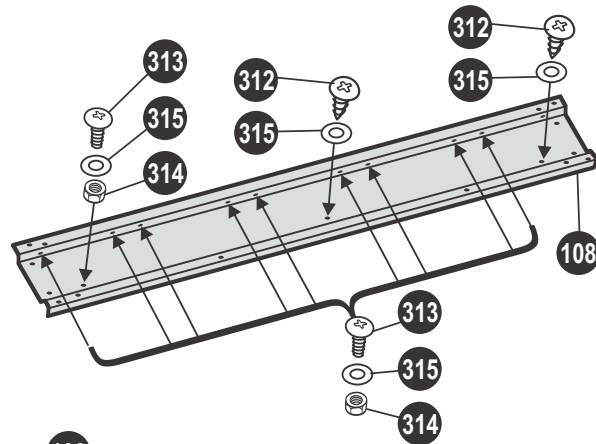

6'

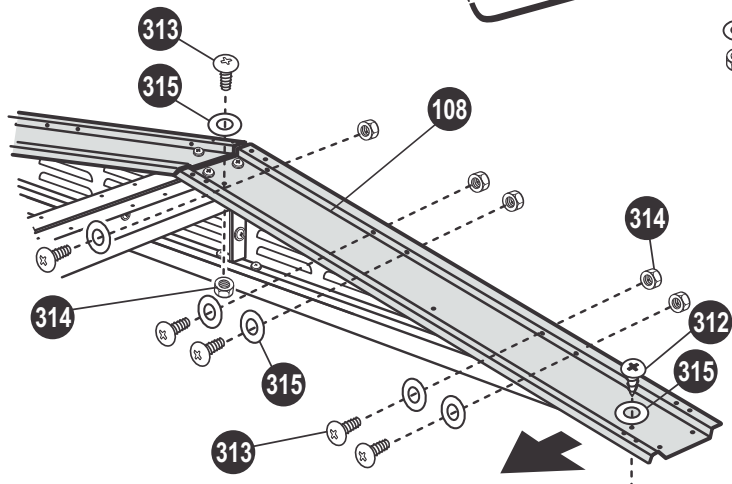

x4

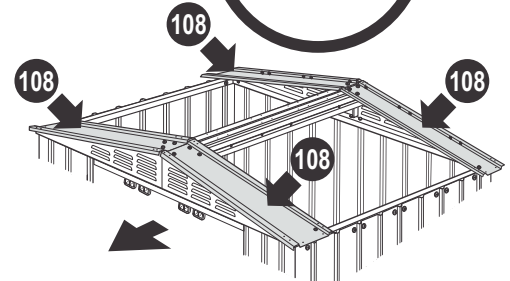

- (GB)** ROOF SHEET CONFIGURATIONS
- (SK)** ZOSTAVA PLECHU KRYTINY
- (HU)** TETŐLAP ALAKZATOK

- (CZ)** KONFIGURACE STŘEŠNÍCH PLÁTŮ
- (PL)** KONFIGURACJE BLACHY DACHOWEJ

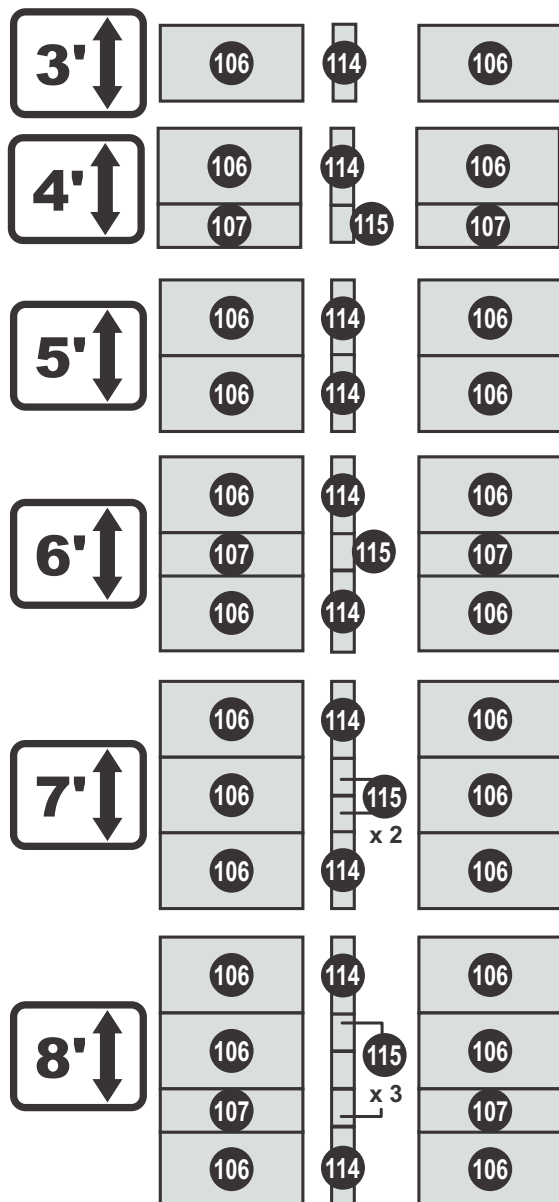

9' height: 106, 106, 106, 106, 114, 115 x 4, 114, 106, 106, 106, 106

10' height: 106, 106, 106, 107, 106, 114, 115 x 5, 114, 106, 106, 107, 106, 106

11' height: 106, 106, 106, 106, 106, 114, 115 x 6, 114, 106, 106, 106, 106, 106

12' height: 106, 106, 107, 106, 106, 106, 114, 115 x 7, 114, 106, 106, 107, 106, 106, 106

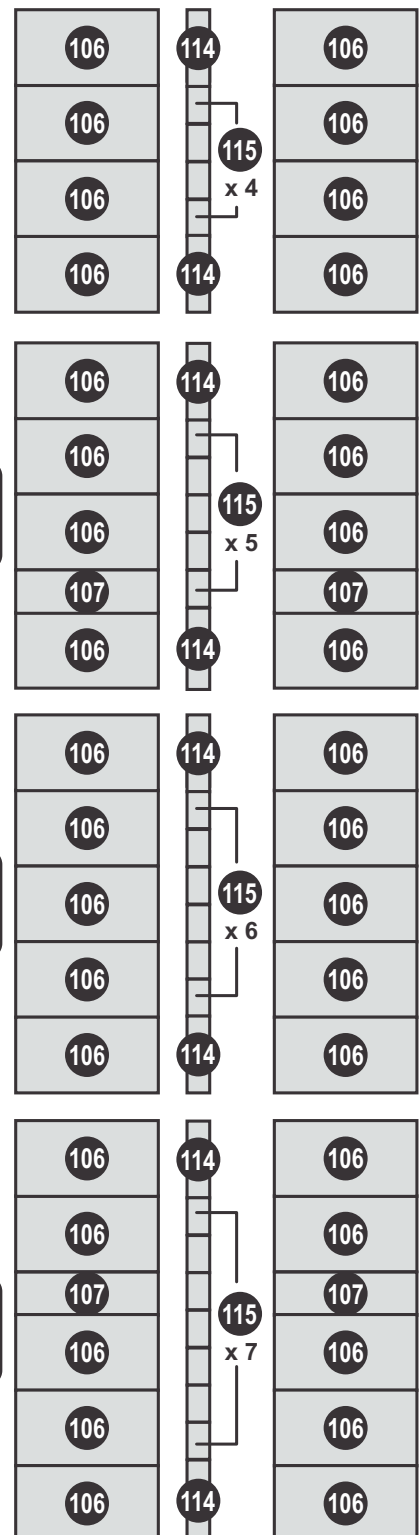

- (GB) IF YOUR SHED INCLUDES SKYLIGHT, FOLLOW INSTRUCTIONS SHOWN HERE. FROM STEP 24.
- (SK) AK MÁ VÁŠ DOMČEK STREŠNÉ OKNO, RIADTE SA TÝMTO NÁVODOM. OD KROKU 24.
- (HU) HA AZ ÖN SUFNIJÁN TETŐABLAK VAN, AKKOR KÖVESSE AZ ITT JELZETT UTASÍTÁSOKAT. A 24. LÉPÉSTŐL
- (CZ) JESTLIŽE VÁŠ DOMEK OBSAHUJE STŘEŠNÍ OKNO SLEDUJTE INSTRUKCE OD BODU 24.
- (PL) JEŚLI TWOJA SZOPA ZAWIERA ŚWIETLIK, POSTĄP ZGONIE Z PRZEDSTAWIONYMI TU INSTRUKCJAMI. OD KROKU 24.

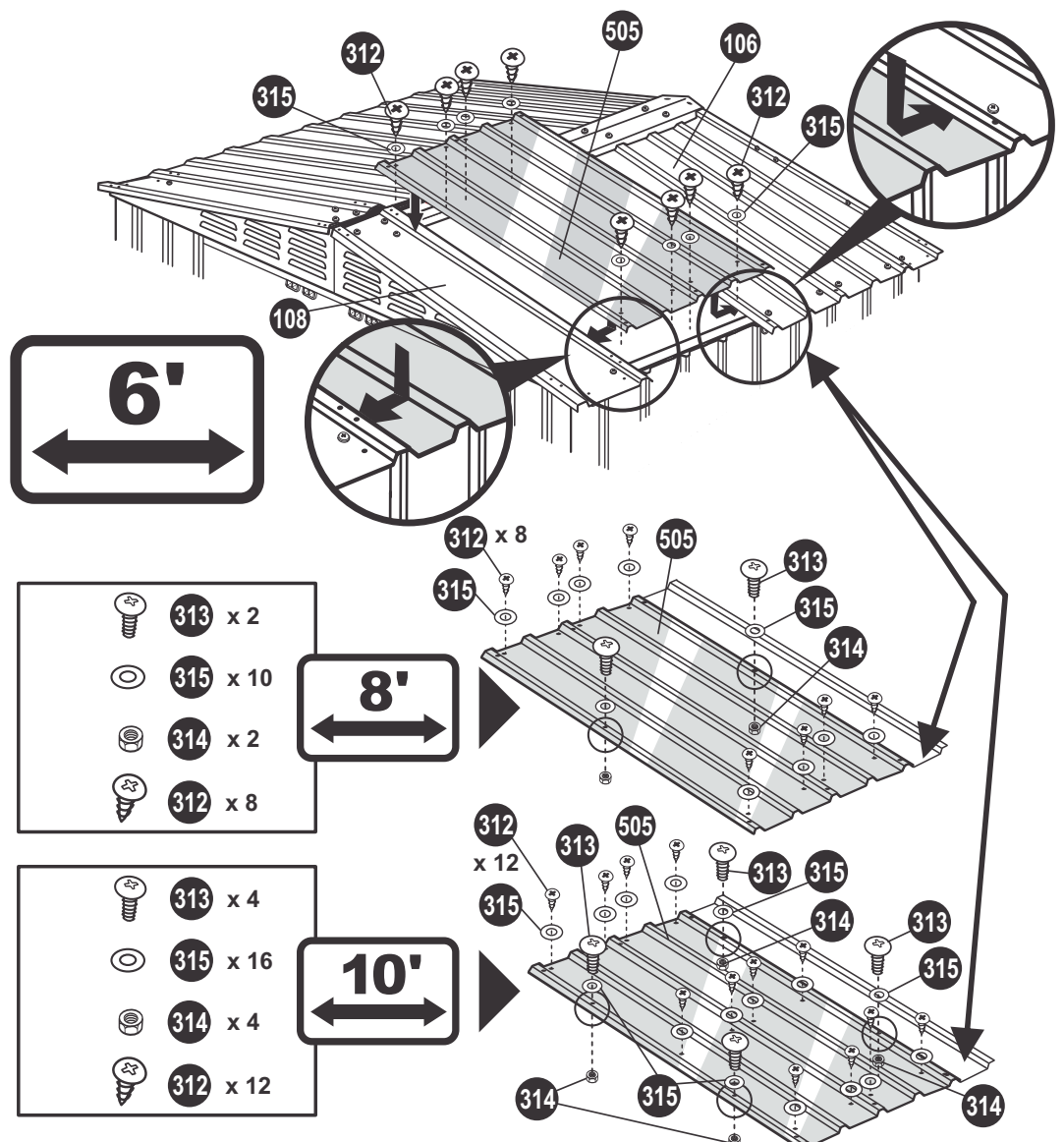
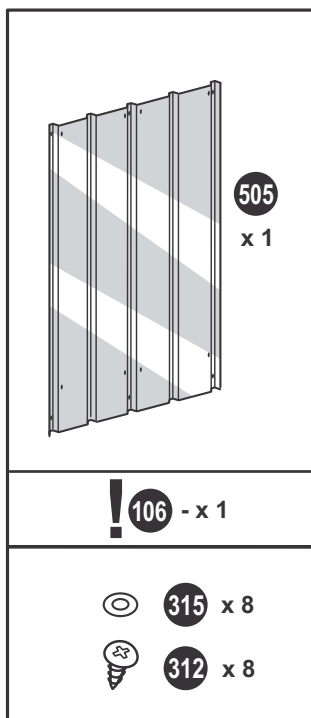

24

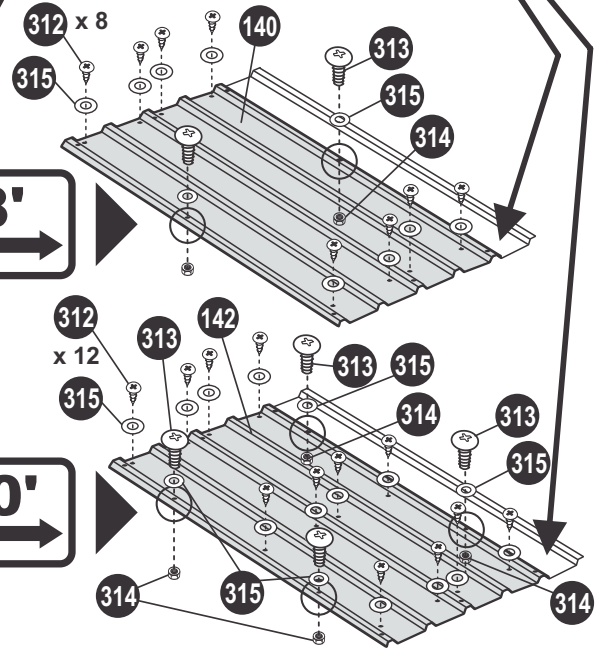
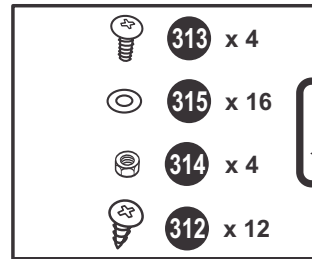
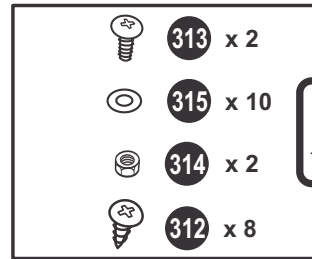
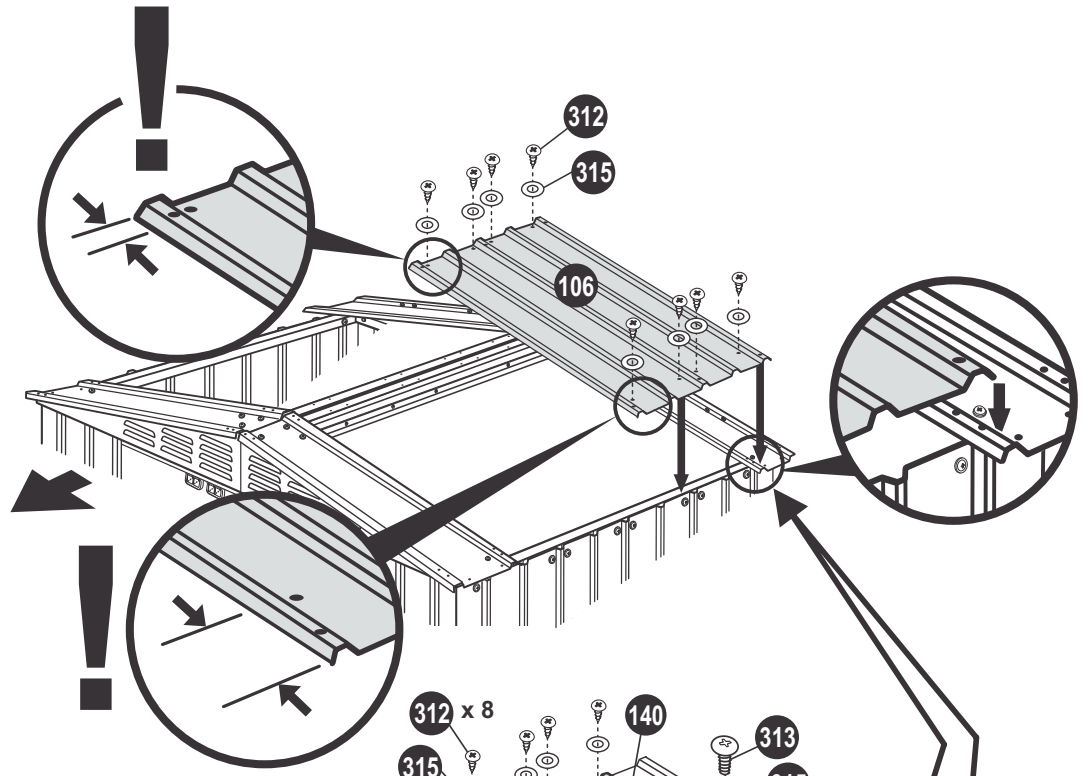
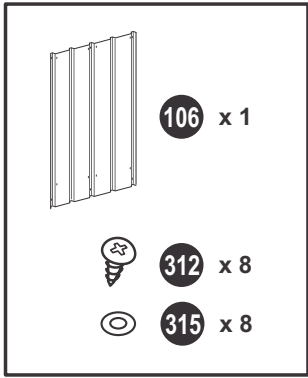

25

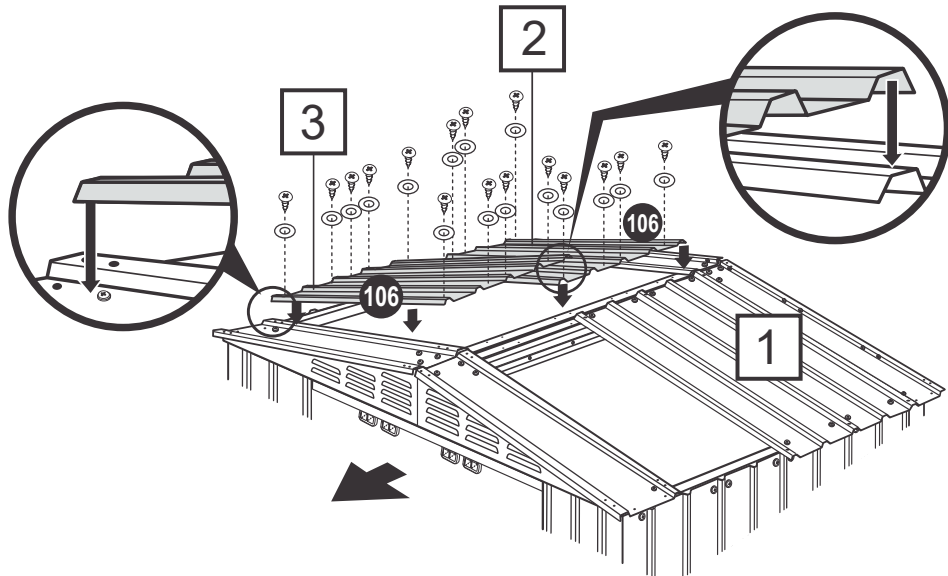
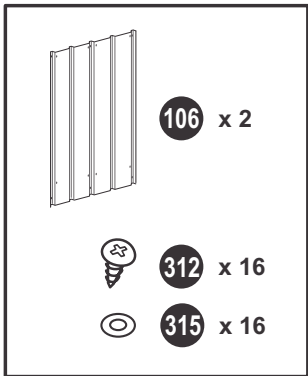

26

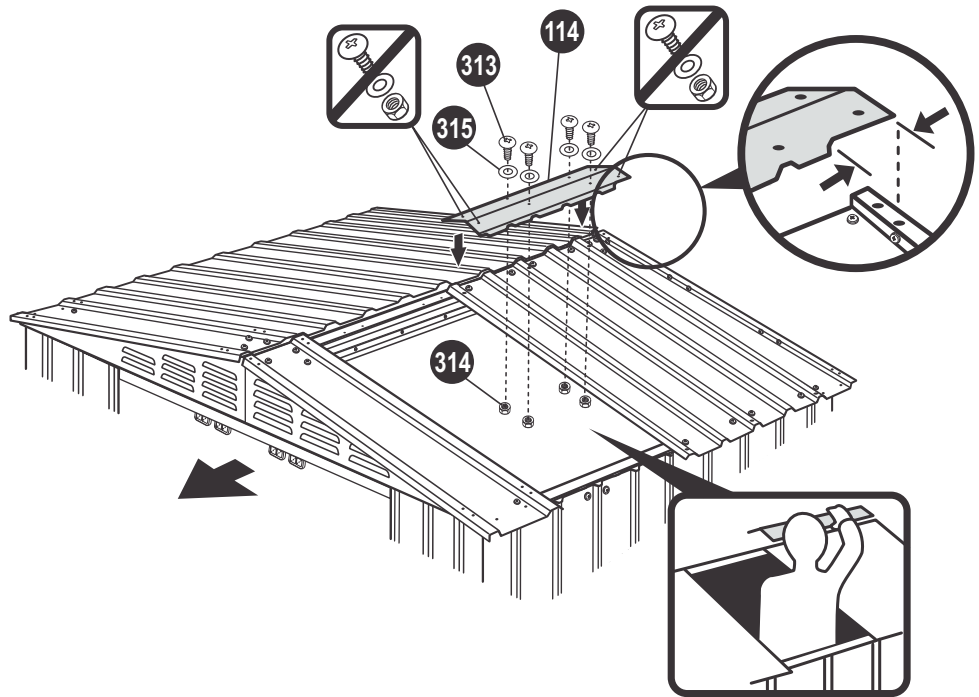
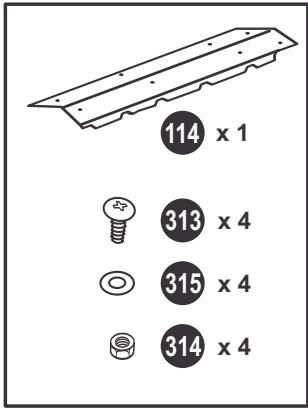

27

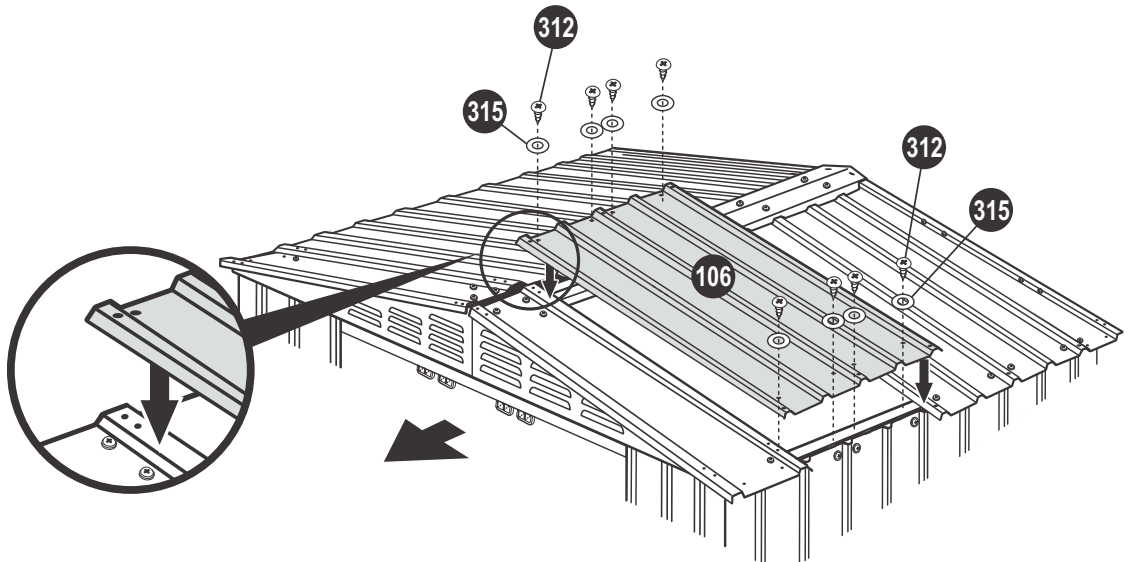
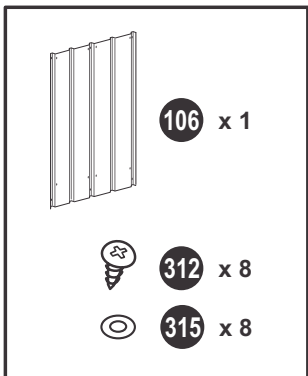

28

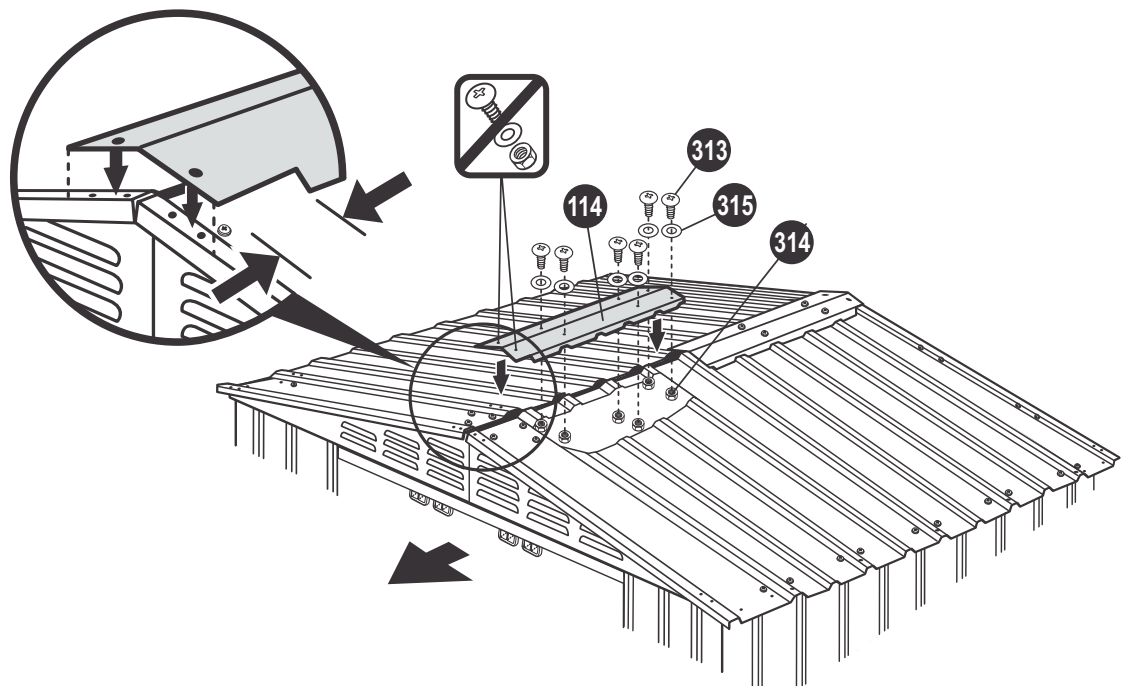
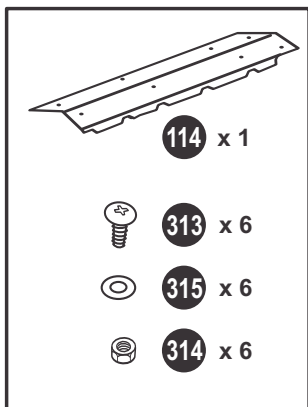

29

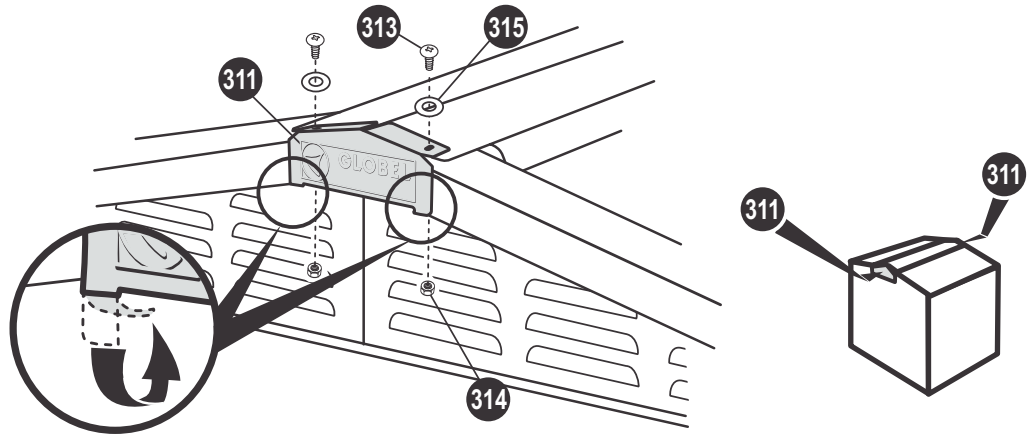
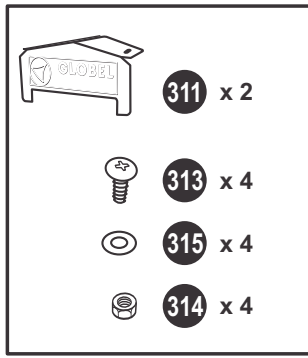

30

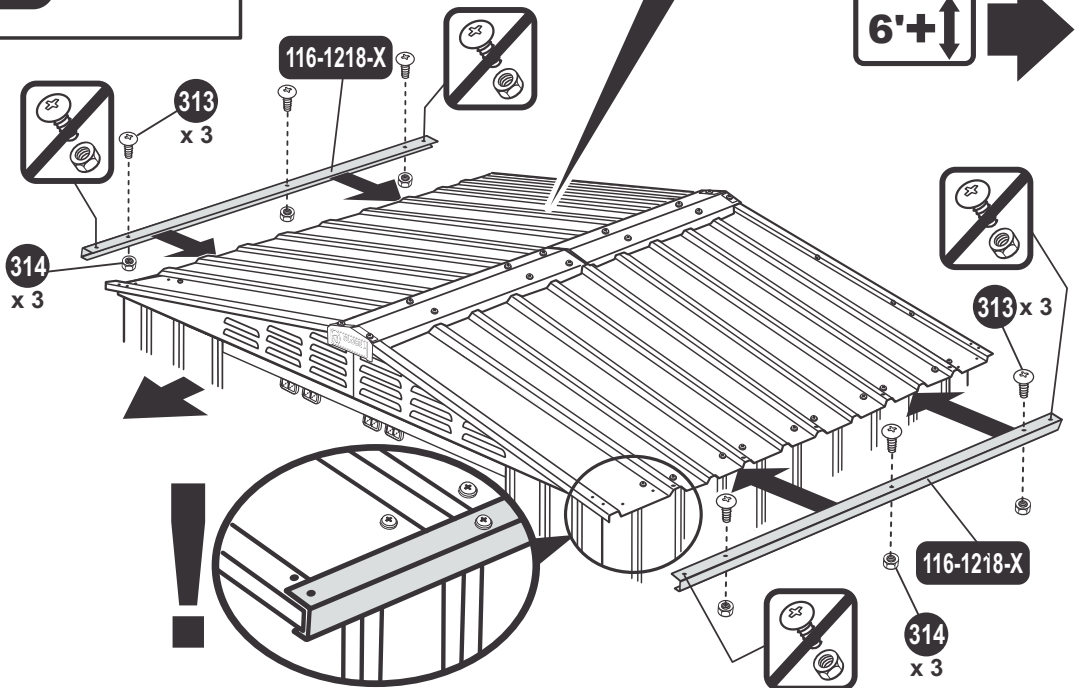
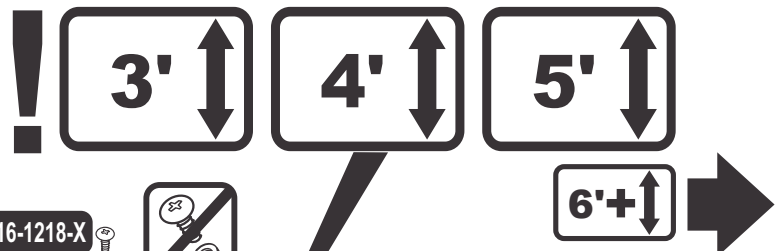
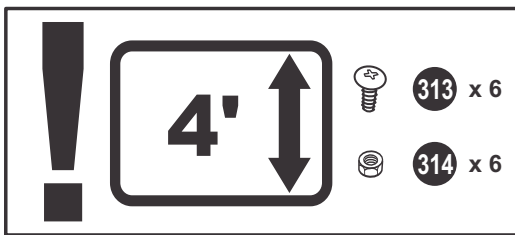
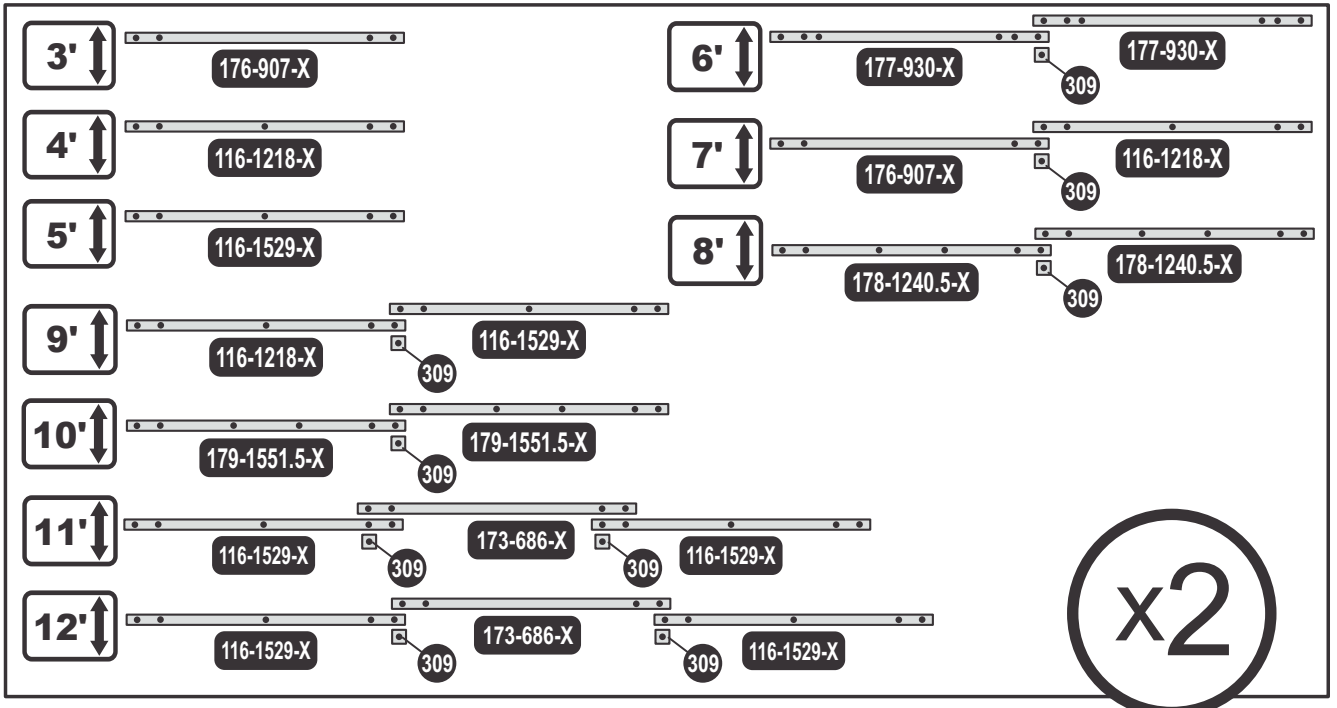

30...

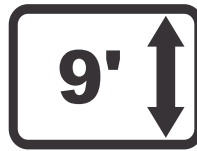

! **6'**

- 309 x 2
- 312 x 2
- 313 x 16
- 314 x 16

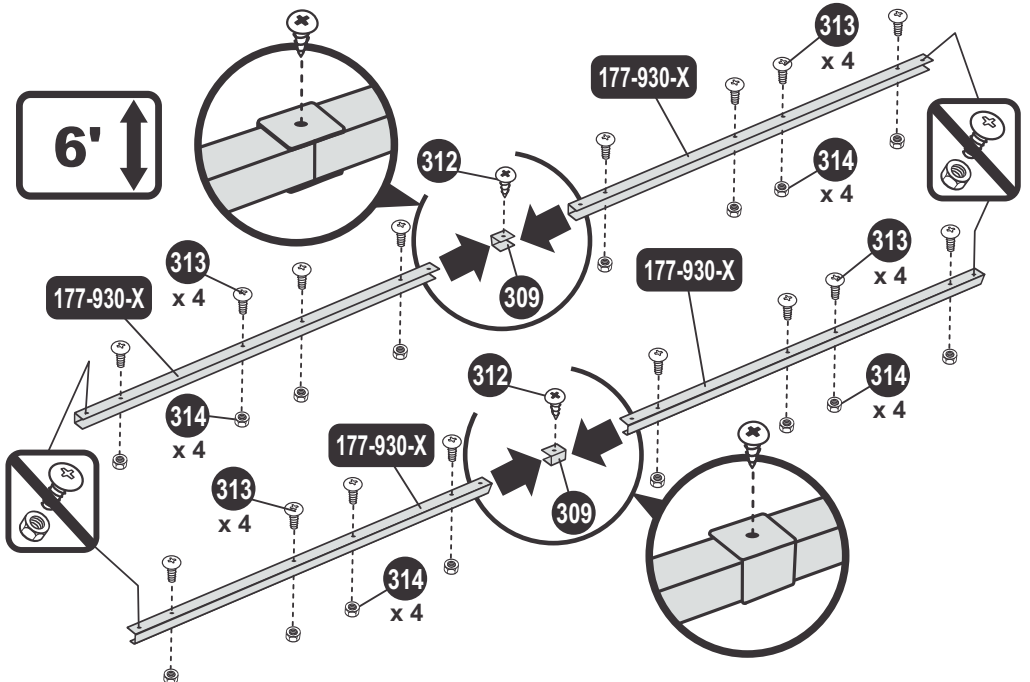

! **12'**

- 309 x 4
- 312 x 4
- 313 x 12
- 314 x 12

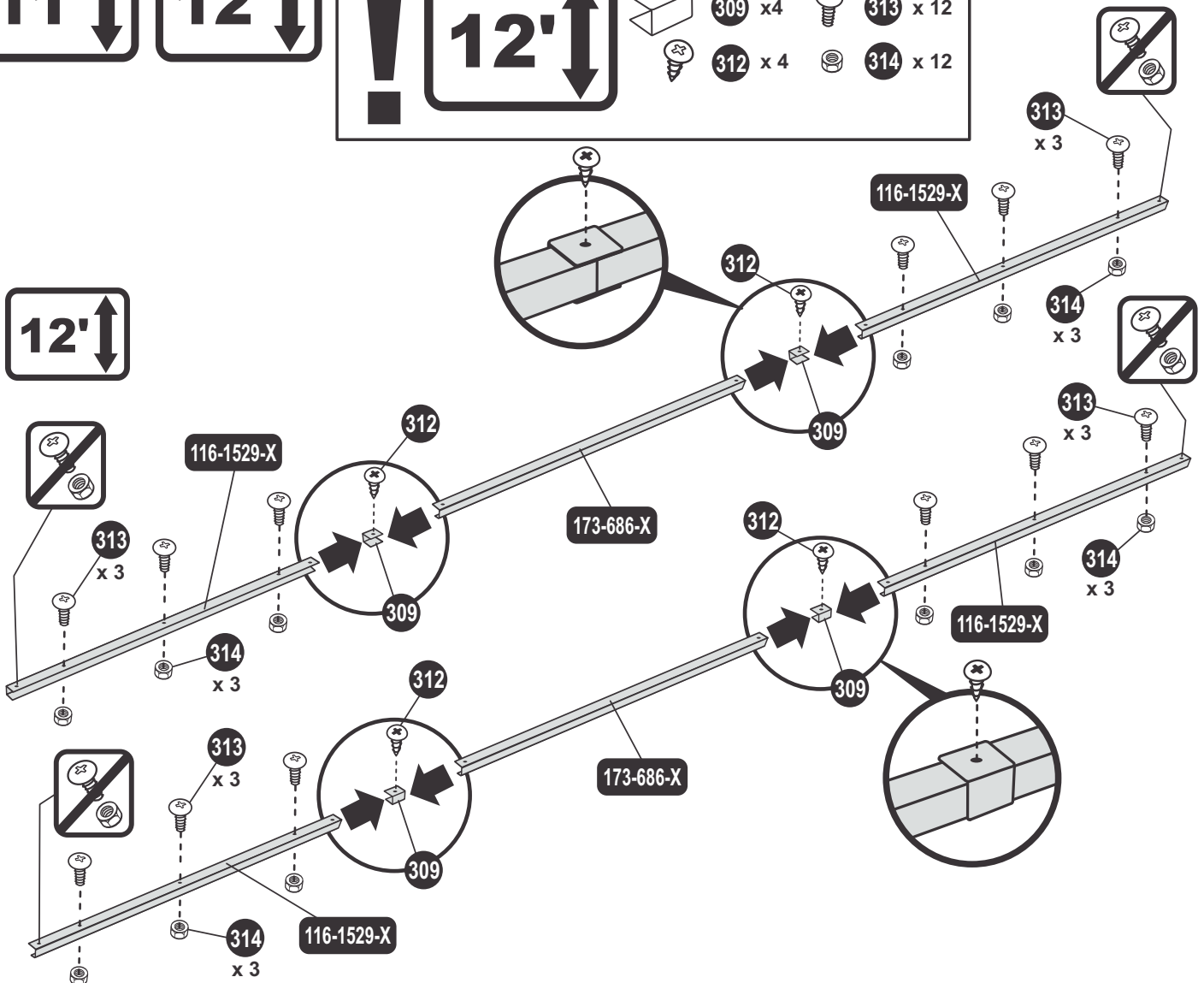

31

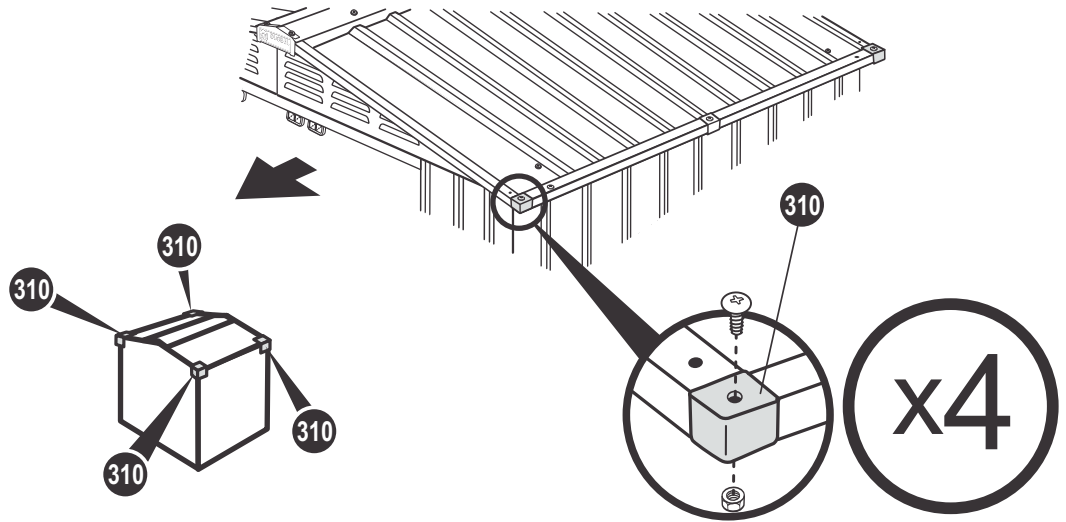
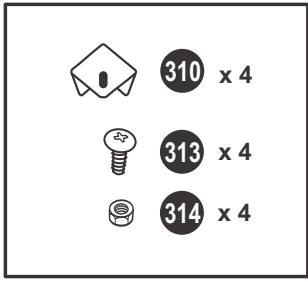



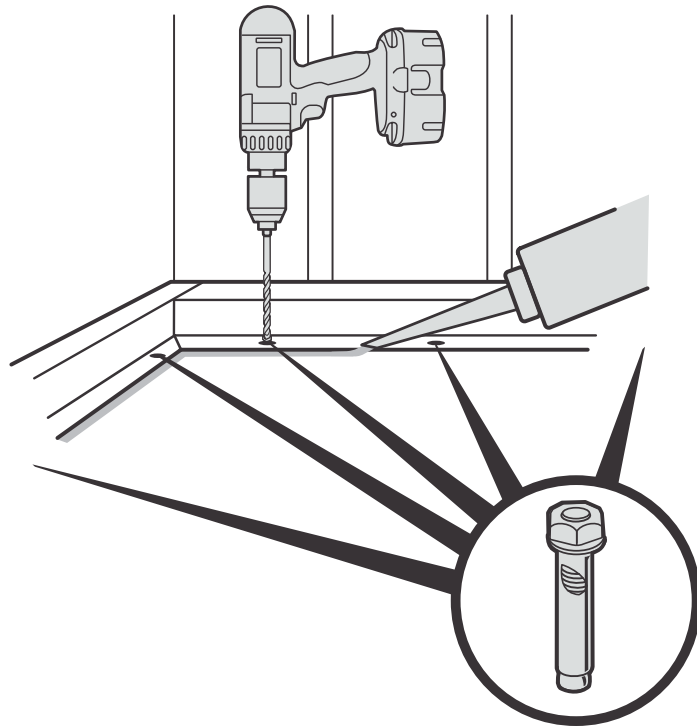

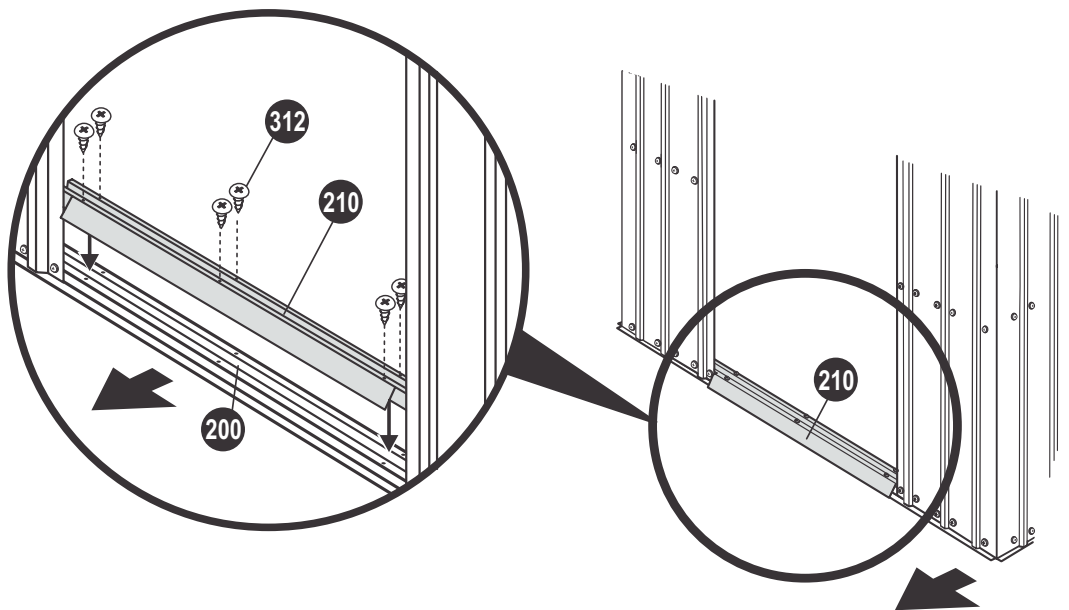
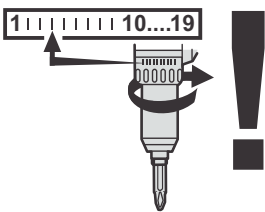
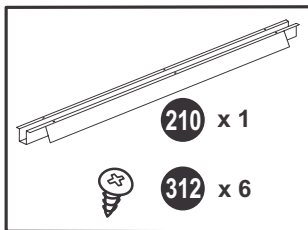

32

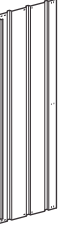





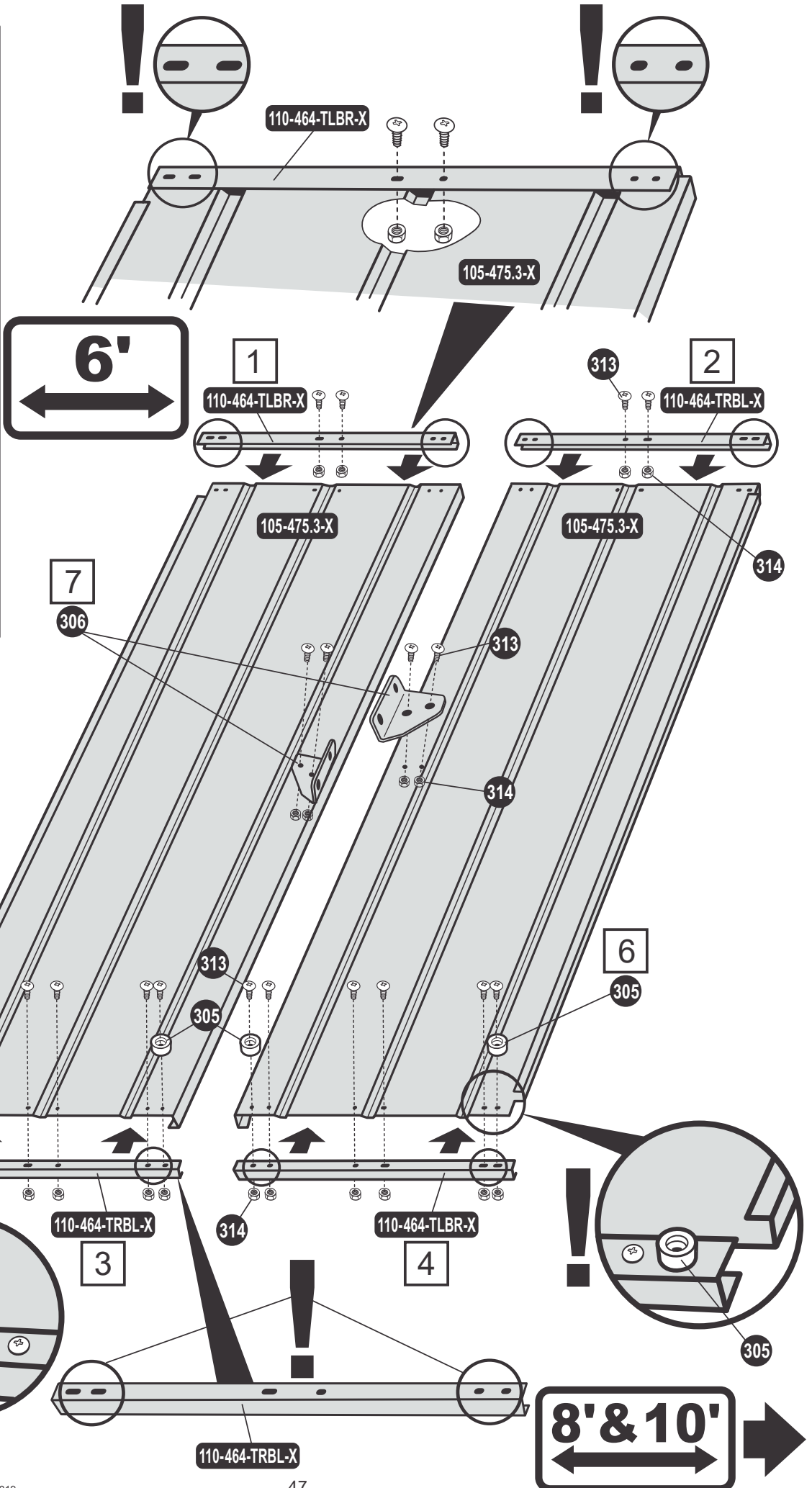

33



-  **105-475.3-X** x 2
-  **110-464-TRBL-X** x 2
-  **110-464-TLBR-X** x 2
-  **306** x 2
-  **305** x 4
-  **313** x 20
-  **314** x 20



34...

-  **105-550-3** x 2
-  **110-520-TRBL-X** x 2
-  **110-520-TLBR-X** x 2
-  **306** x 2
-  **305** x 4
-  **313** x 28
-  **314** x 28

8'

10'

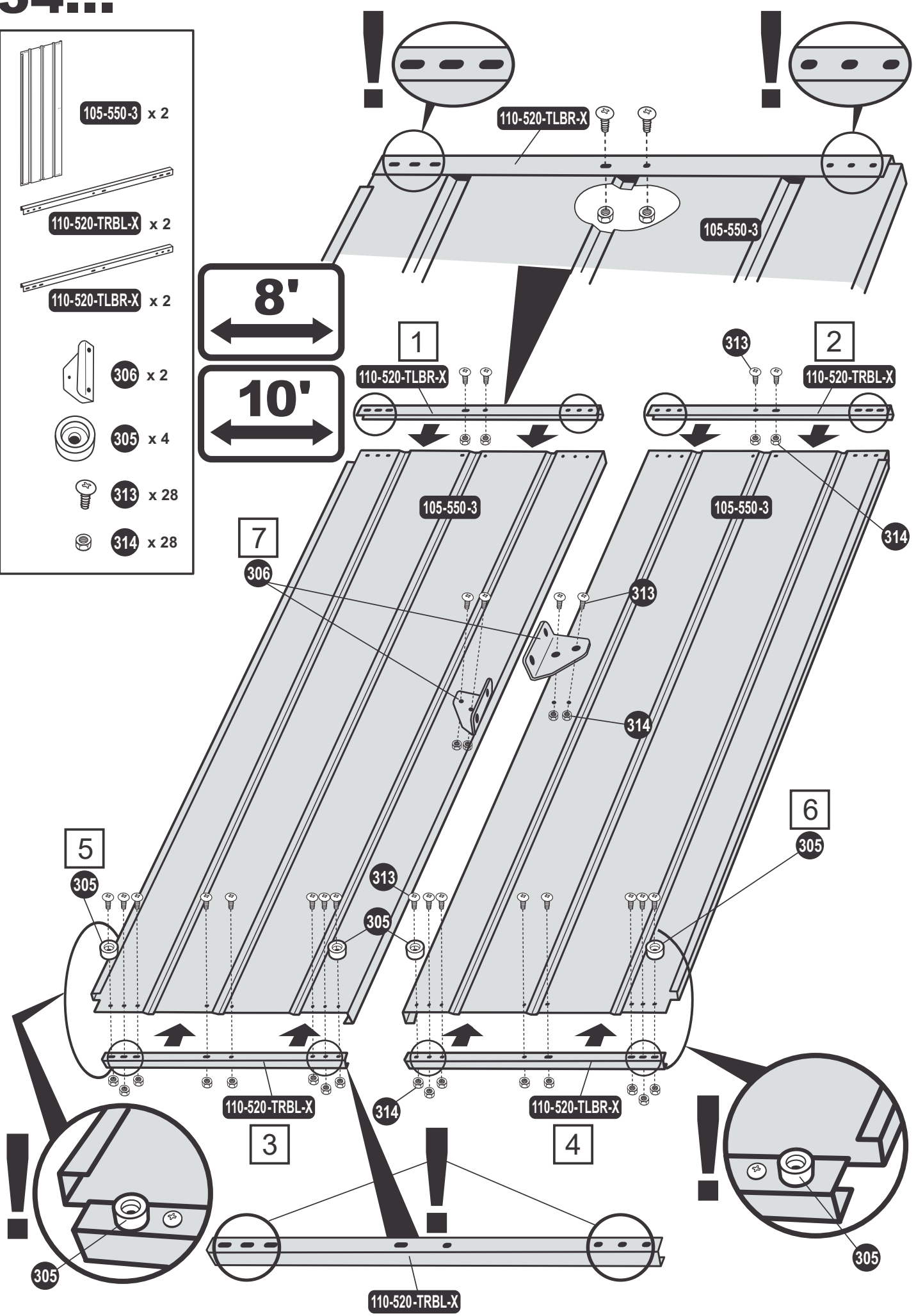
35

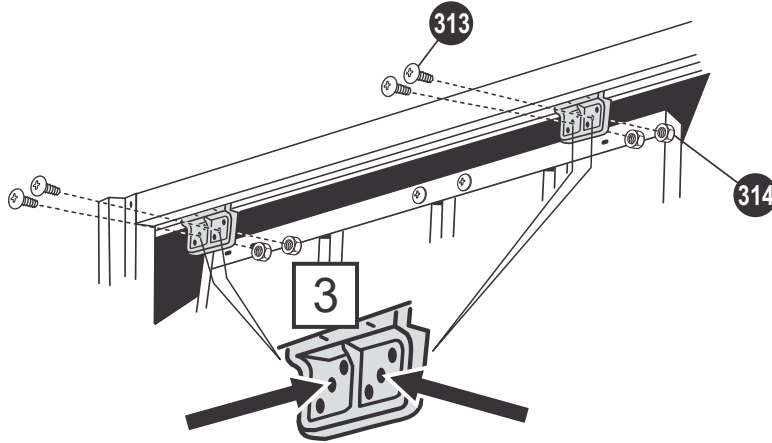
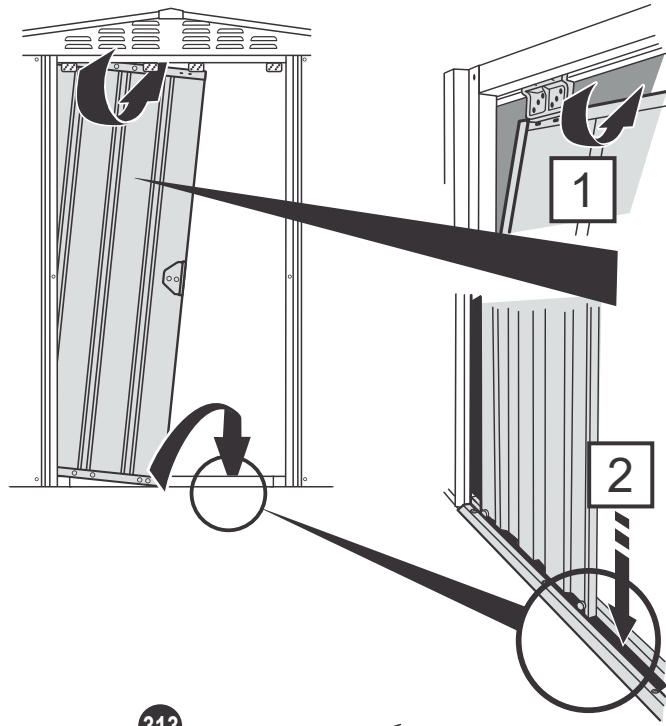
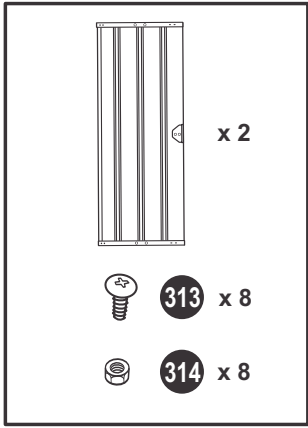

36

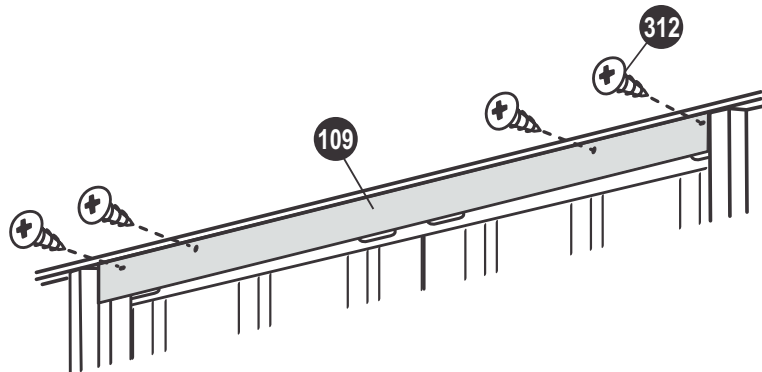
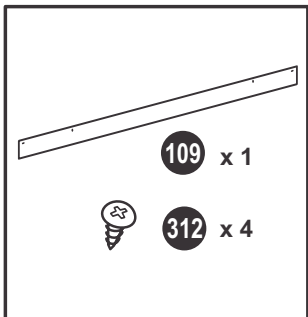

STAPLE ORIGINAL
PURCHASE RECEIPT
HERE

WARRANTY - 15 YEAR (LIMITED)

1. Copy of original purchase receipt required.
2. Globel Sheds are for domestic use only and must be installed as per steps and procedures in assembly instructions.
3. Colour variations arising from natural weathering is not covered by warranty, nor are forces of nature and other causes which are beyond Globel Sheds control.
4. Installation of shed in ocean locations, heavy industrial or unusually corrosive environments voids warranty.
5. Warranty does not apply if proven that a third party contaminate contributed to fault.
6. Warranty void if shed backfilled.
7. Warranty not transferrable.
8. Fasteners, door glides, plastic parts not covered by warranty.
9. Missing components must be claimed within 14 days of purchase.
10. For any warranty claim you must contact original place of purchase.
11. Any expenses incurred by claimant in conducting their claim will be at expense of claimant.
12. Any expenses and/or labour incurred costs by claimant for purpose of replacement and/or fixing any parts to shed will be at claimants expense.

/ /

PURCHASE DATE

PLACE

MODEL / PRODUCT CODE

PŘIPEVNĚTE
PŮVODNÍ PRODEJNÍ
DOKLAD ZDE

ZÁRUKA - 15 LET (OMEZENÁ)

1. Je zapotřebí mít původní prodejní doklad.
2. Globel zahradní domky jsou pouze pro domácí použití a musí být instalovány podle bodů a pokynů v návodu na instalaci.
3. Barevné změny způsobené přirozeným zvětráním nejsou pokryté zárukou ani síly přírody a další příčiny, které jsou mimo kontrolu Globel zahradních domků.
4. Instalace domku v místech u moře, těžkého průmyslu nebo neobvykle korozivního prostředí, zneplatní záruku.
5. Záruku nelze uplatnit, když bylo dokázáno že třetí strana přispěla k závadě.
6. Záruka je neplatná jestliže je domek na navážce.
7. Záruka je nepřenosná.
8. Spojovací prvky, drážky na šoupací dveře, plastické součástky nejsou pokryty zárukou.
9. Chybějící součástky se musí urgovat do 14 dnů po zakoupení.
10. S jakoukoliv pohledávkou na záruku se musíte obrátit na původní místo zakoupení.
11. Jakékoliv výdaje které vyvstaly žadateli uplatňující nárok ponese žadatel.
12. Jakékoliv výdaje a /nebo pracovní náklady žadatele za účelem výměny a/nebo připevnění jakékoliv součástky k zahradnímu domku nese žadatel .

/ /

DATUM ZAKOUPENÍ

MÍSTO

MODEL/ KÓD VÝROBKU

TU PRIPNÚŤ ORIGINAL
PREDAJNÉHO BLOČKU**ZÁRUKA - 15 ROKOV**

1. Kópia pôvodného predajného bločku je potrebná.
2. Záhradné domčeky Globel slúžia len na domáce účely a musia byť postavené podľa krokov a postupov v montážnom návode.
3. Záruka sa nevzťahuje na zmeny farby zapríčinené poveternostnými podmienkami, alebo inými príčinami, ktoré sú mimo kontroly domčeka Globel.
4. Záruka sa nevzťahuje na domčeky postavené blízko oceánu, ťažkých priemyselných alebo ničivých prostrediach.
5. Záruka je neplatná ak sa dokáže, že poškodenie tretej strany prispelo k závade.
6. Záruka je neplatná v prípade, že domček je zasypaný.
7. Záruka je neprenosná.
8. Záruka nepokrýva upínadla, dverové pánty a plastové časti.
9. Chýbajúce časti musia byť nahlásené do 14 dní od zakúpenia.
10. Akákoľvek reklamácia musí byť podaná na pôvodnom mieste nákupu tovaru.
11. Osoba podávajúca reklamáciu musí uhradiť akékoľvek náklady, ktoré vzniknú pri podaní reklamácie.
12. Akékoľvek výdavky, alebo pracovné náklady, ktoré vzniknú za účelom náhrady, alebo opravy častí domčeka musia byť uhradené osobou, ktorá podáva reklamáciu.

/ /
DÁTUM NÁKUPU

MIESTO

MODEL/KÓD VÝROBKU

PRZYPNIJ TUTAJ
ORYGINALNE
POKWITOWANIE ZAKUPU**GWARANCJA - 15 LAT (OGRANICZONA)**

1. Wymagana jest kopia oryginalnego pokwitowania zakupu.
2. Globel Sheds służą jedynie do domowego użytku i muszą zostać zainstalowane zgodnie z krokami i procedurami przedstawionymi w instrukcjach montażu.
3. Zmiany odcieni powstałe w wyniku warunków atmosferycznych, podobnie jak sił natury i innych przyczyn niezależnych od Globel Sheds nie są objęte gwarancją.
4. Instalacja szopy w miejscach nad morzem oraz w środowiskach przemysłowych i szczególnie korozyjnych unieważnia gwarancję.
5. Gwarancja nie obowiązuje, jeśli zostanie dowiedzione, że zanieczyszczenie przez trzecią stronę przyczyniło się do uszkodzenia.
6. Gwarancja nie obowiązuje, jeżeli szopa zostanie zasypana.
7. Gwarancja nie jest przenośna.
8. Łączniki, prowadnice drzwi i części plastikowe nie są objęte gwarancją.
9. Brakujące komponenty muszą zostać zgłoszone w ciągu 14 dni od zakupu.
10. Dla każdego roszczenia z tytułu gwarancji należy się skontaktować z miejscem zakupu.
11. Wszelkie wydatki poniesione przez zgłaszającego reklamację w toku reklamacji ponosi zgłaszający reklamację.
12. Wszelkie wydatki i/lub koszty poniesione przy pracy przez zgłaszającego reklamację w celu wymiany i/lub naprawy jakichkolwiek części szopy ponosi zgłaszający reklamację.

/ /
DATA ZAKUPU

MIEJSCE

MODEL/KOD PRODUKTU

CSATOLJA AZ
EREDETI VÁSÁRLÁSI
ELISMERVÉNYT IDE

GARANCIA - 15 ÉV (KORLÁTOLT)

1. Az eredeti vásárlási elismervény másolata szükséges.
2. Globel sufnik csak házi használatra készültek és azokat az összeszerelési utasítások szerinti lépések és eljárás alapján kell összeállítani.
3. A garancia nem takarja az időjárás okozta színváltozásokat valamint az természeti erőket és az egyéb okokat, amelyek a Globel Sheds irányításán kívül állnak.
4. A garancia érvénytelen, ha a nyílt tenger közelében, nehézipari vagy szokatlanul korrozív környezetben állítják fel a sufnit.
5. A garancia nem érvényes, ha egy harmadik személy szennyezése járult hozzá a hibához.
6. A garancia nem érvényes, ha a kiásott anyaggal töltik fel.
7. A garancia nem átutalható.
8. A garancia nem takar tolózárakat, plastik alkatrészeket, ajtócsuszatókat.
9. A hiányzó alkatrészeket a vétel utáni 14 napon belül reklamálni kell.
10. A garancia alatti igényt ott kell jelenteni, ahol eredetileg vette.
11. Az igénylő felel az igényvel kapcsolatos költségért, amelyet kiad.
12. Az igénylő felel azért a költségért vagy munkadíjért, amelyet kicserélés céljából vagy a sufni részének javítására kiad.

/ /

VÉTEL IDEJE

HELYE

MODEL/ TERMÉK KÓD

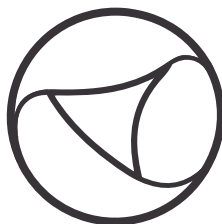

GLOBEL®

www.globelindustries.com